



Government of India

Phone: +912225595176

परमाणु ऊर्जा विभाग  
Department of Atomic Energy  
वैश्विक नाभिकीय ऊर्जा साझेदारी केन्द्र

GLOBAL CENTRE FOR NUCLEAR ENERGY PARTNERSHIP



Ref: GCNEP/MoEF/

Dated: 14.08.15

To,  
Regional Office,  
Ministry of Environment & Forest (Northern Region)  
Bays No: 24-25, Sector-31 A,  
Dakshin Marg, Chandigarh-160030

Sub: Half Yearly Compliance Report (Session:- November 2014 to June 2015) of the stipulated Environmental Conditions/Safeguards in the Environmental Clearance Letter and Environmental Monitoring Report of Institutional Campus and Residential Township for Global Center for Nuclear Energy Partnership (GCNEP) at Village Kheri Jasaur and Jasaur Kheri, District Jhajjar, Haryana by GCNEP.

Ref: Environmental Clearance No. SEIAA/HR/2014/1385 Dated 7<sup>th</sup> November 2014

Dear Sir,

This is in reference to the above mentioned Environmental Clearance No. SEIAA/HR/2014/1385 Dated 7<sup>th</sup> November 2014 in which we have been asked to submit the compliance with the specific and general conditions of the same.

In view of above, we are approaching you by submitting a copy of the following information/ documents for your kind perusal:

1. Point-wise compliance of the stipulated environmental conditions/ safeguards, along with necessary documents & annexures.
2. Environmental monitoring report.

We fully assure you that we will comply with all conditions as specified in the Environment clearance granted to us.

Thanking you,

Yours Sincerely,

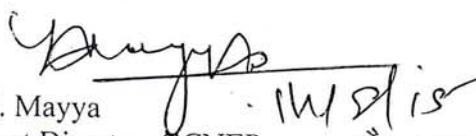
  
Y. S. Mayya  
Project Director, GCNEP  
BARC, Mumbai-400085  
Email: [ysmayya@barc.gov.in](mailto:ysmayya@barc.gov.in)

वै. एस. मय्या / Y. S. Mayya  
परियोजना निदेशक / Project Director  
जी सी एन ई पी, डी ए र्व / GCNEP, DAE  
भारत सरकार, डी. ए. आर. सी / Govt. of India B.A.R.C.  
मुंबई-४०० ०८५. / Mumbai - 400 085.

- CC: 1. The Member Secretary, Haryana State Pollution Control Board, Panchkula, Haryana.  
2. The Secretary SEIAA, Bay No.55-58, Parytan Bhawan 1<sup>st</sup>Floor Sector-2, Panchkula, Haryana.

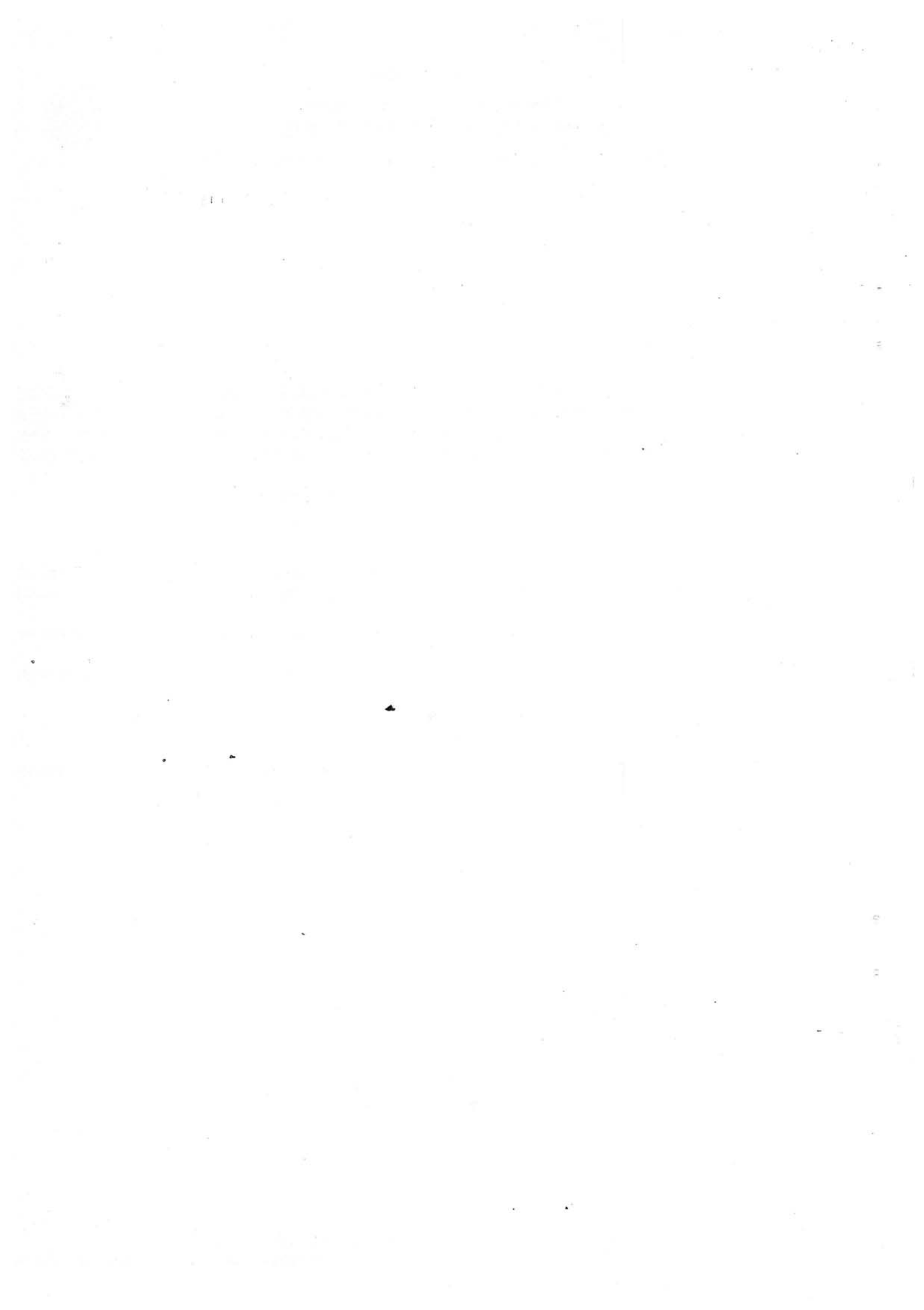

LIST OF ANNEXURES

ANNEXURE I	CTE
ANNEXURE II	Photograph showing First Aid Room
ANNEXURE III	Photograph showing Drinking water, toilet and septic tank
ANNEXURE IV	Solid waste Management
ANNEXURE V	Photograph showing top soil storage
ANNEXURE VI	Photograph showing covered construction material
ANNEXURE VII	Lab reports
ANNEXURE VIII	Photograph showing Fly Ash Brick
ANNEXURE IX	Photograph showing Batching Plant
ANNEXURE X	Energy Conservation Plan
ANNEXURE XI	Forest NOC
ANNEXURE XII	Fire NOC
ANNEXURE XIII	Electricity Permission
ANNEXURE XIV	No Ground water extraction undertaking
ANNEXURE XV	Photograph showing Site Barricading
ANNEXURE XVI	Photograph showing Water sprinkling
ANNEXURE XVII	Photograph showing Proper rasta
ANNEXURE XVIII	Site Plan
ANNEXURE XIX	Traffic cum Parking Plan
ANNEXURE XX	Advertisement
ANNEXURE XXI	EC Letter

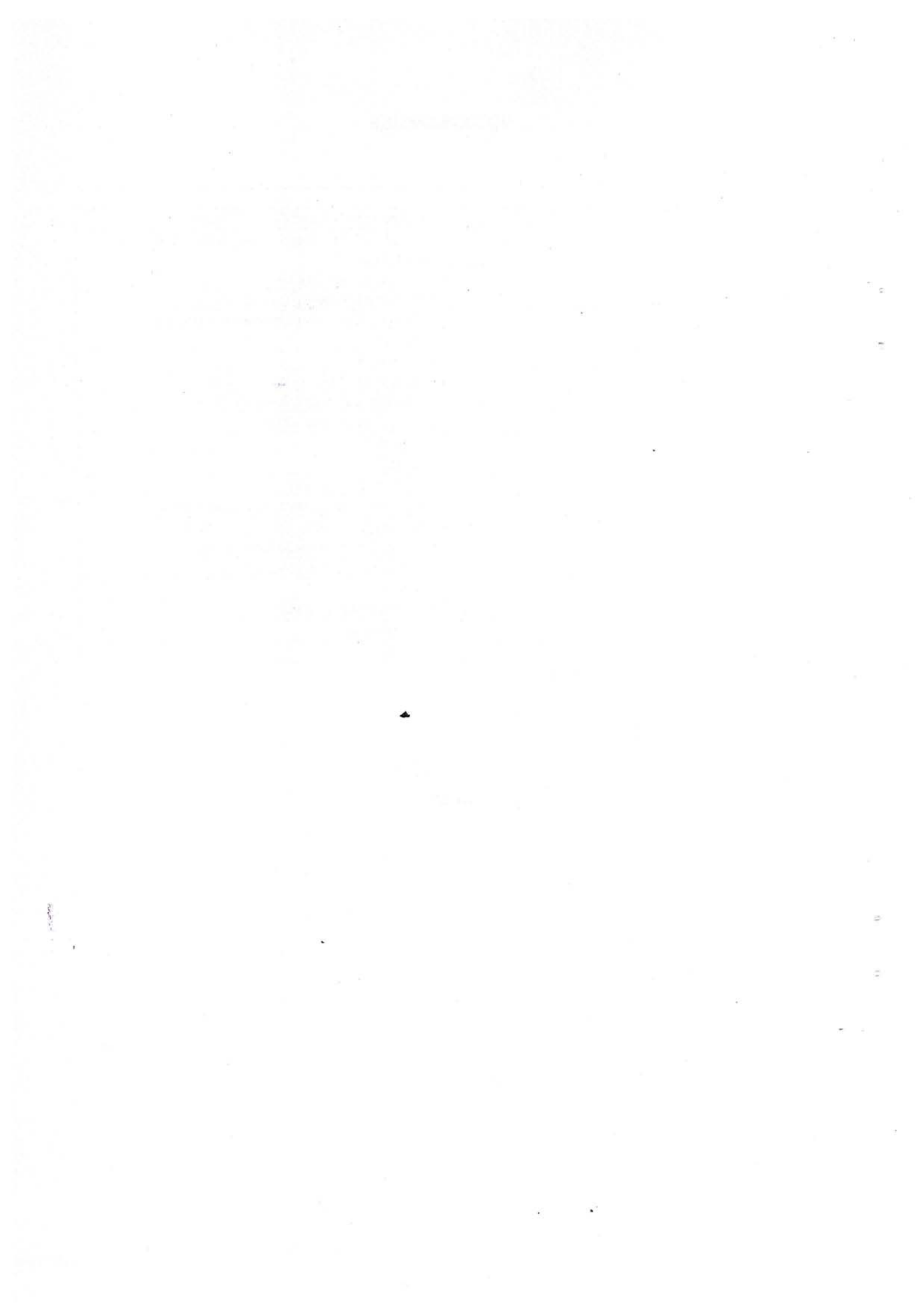

**HALF YEARLY COMPLIANCE OF STIPULATED  
ENVIRONMENTAL CONDITIONS/ SAFEGUARDS IN THE  
ENVIRONMENTAL CLEARANCE LETTER NO. SEIAA/HR/2014/1385**

**DATED 7<sup>th</sup> November 2014**

**FOR**

**INSTITUTIONAL CAMPUS AND RESIDENTIAL TOWNSHIP FOR GLOBAL  
CENTER FOR NUCLEAR ENERGY PARTNERSHIP (GCNEP) AT VILLAGE KHERI  
JASOUR AND JASOUR KHERI, DISTT. JHAJJAR, HARYANA**

SL. NO.	CONDITIONS	STATUS OF COMPLIANCE
<b>PART A - SPECIFIC CONDITIONS: Construction Phase:-</b>		
1.	“Consent to Establish” shall be obtained from Haryana State Pollution Control Board under Air and Water act and a copy shall be submitted to the SEIAA Haryana before the start of any construction work at the site.	Consent to Establish has been obtained from Haryana State Pollution Control Board for “Consent to Establish” under Air and Water Act vide letter no. <b>HSPCB/Consent/: 2821215JHACTE1432687 dated .27.02.2015.</b> Copy of CTE is enclosed as <b>Annexure I.</b>
2.	A first aid room as proposed in the project report shall be provided both during construction and operation phase of the project.	<b>Agreed.</b> First Aid room has already been provided at the site for construction as well as the same will be provided for operation phase. We are doing routine medical check-up for the labourers those who are working at the construction site. Photograph showing First Aid room are attached as <b>Annexure II.</b>
3.	Adequate drinking water and sanitary facilities should be provided for construction workers at the site. Provision should be made for mobile toilets. Open defecation by the laborers is strictly prohibited. The safe disposal of waste	<b>Agreed.</b> An adequate drinking water facility and toilet has been provided at the project site for construction workers. The open defecation by the labors is strictly prohibited. The wastewater generated during construction phase is being sent to septic tanks.

वै. यश. मय्या / **Y. S. Mayya**

Page 1

परियोजना निदेशक / Project Director

जी सी एन ई पी. टी ए ई / GCNEP, DAE

भारत सरकार, जी. ए. आर. सी. / Govt. of India B.A.R.C.

मुंबई-४०० ०८५. / Mumbai - 400 085.



	water and solid wastes generated during the construction phase should be ensured.	Photographs showing drinking water facility, toilets and septic tank are attached as <b>Annexure III</b> . Left over cement and mortar, cement concrete blocks, aggregates, sand and other inorganic material are being recycled. Solid waste management plan is enclosed as <b>Annexure IV</b> .
4.	All the topsoil excavated during construction activities should be stored for use in horticulture/ landscape development within the project site.	<b>Agreed.</b> Top soil has been excavated and stored in the nearby area at project site will be used later for landscaping purpose. Photograph showing the same is enclosed as <b>Annexure V</b> .
5.	The project proponent shall ensure that the building material required during construction phase is properly stored within the project area and disposal of construction waste should not create any adverse effect on the neighboring communities and should be disposed of after taking the necessary precautions for general safety and health aspects of people, only in approved sites with the approval of competent authority.	<b>Agreed.</b> No significant muck excavation is being done at the project site. Construction materials are being properly stored within project site. Photograph showing covered construction material enclosed as <b>Annexure VI</b> .
6.	Construction spoils, including bituminous material and other hazardous materials, must not be allowed to contaminate watercourses and the dump sites for such material must be secured so that they should not leach into the ground water and any hazardous waste generated during construction phase, should be disposed off as per applicable rules and norms with	<b>Agreed.</b> Construction spoils such as bituminous material and other hazardous materials are not allowed to contaminate water courses. Hazardous waste generated during construction phase, is being disposed off as per applicable rules and norms.

	necessary approval of the Haryana State Pollution Control Board.	
7.	The diesel generator sets to be used during construction phase should be of low sulphur diesel type and should conform to Environment (Protection) Rules prescribed for air and noise emission standards.	<b>Agreed.</b> D.G sets are running on low sulphur diesel only. D.G sets are being used for office lighting. Results of Environmental monitoring carried out at the site for Air and Noise monitoring are enclosed as <b>Annexure VII.</b>
8.	The diesel required for operating DG sets shall be stored in underground tanks and if required, clearance from Chief Controller of Explosives shall be taken.	<b>Agreed.</b> D.G sets are used only for lighting purpose. The quantity of diesel required is very low. So, storage of diesel is not proposed.
9.	Ambient noise levels should conform to the residential standards both during day and night. Incremental pollution loads on the ambient air and noise quality should be closely monitored during construction phase. Adequate measures should be made to reduce ambient air and noise level during construction phase, so as to conform to the stipulated standards.	<b>Agreed.</b> Ambient noise levels are monitored during day & night and conforming to standards. Base line + incremental load of Ambient Air Quality and Noise Level are being closely monitored during construction phase. Adequate measures have been adopted to reduce Ambient Air Quality Level and Noise Level during construction phase to conform to the stipulated standards. Ambient air quality report and noise monitoring report is enclosed as <b>Annexure VII.</b>
10.	Fly ash should be used as building material in the construction as per the provisions of Fly Ash Notification of September, 1999 and amended as on 27 <sup>th</sup> August, 2003.	The construction agencies will use fly ash based bricks for the construction of walls. Photograph showing same is enclosed as <b>Annexure VIII.</b>
11.	Storm water control and its re-use as per CGWB and BIS standards for various applications should be ensured.	<b>Agreed.</b> Standards shall be followed.

डै. यस्. मय्या / Y. S. Mayya

परियोजना निदेशक / Project Director

जी सी एन ई पी, डी ए ई / GCNEP, DAE

भारत सरकार, वी. ए. आर. सी. / Govt. of India B.A.R.C.

मुंबई-४०० ०८५. / Mumbai - 400 085.

Page 3



12.	Water demand during construction should be reduced by use of premixed concrete, curing agents and other best practices as referred.	<b>Agreed.</b> Water demand during construction is being reduced by the practice of using premixed concrete. Photograph showing batching plant at site is shown as <b>Annexure IX.</b>
13.	Roof should meet prescriptive requirement as per Energy Conservation Building Code by using appropriate thermal insulation material to fulfill requirement.	<b>Agreed.</b> Roof will meet the prescriptive requirement as per energy conservation building code by using appropriate thermal insulation material. Energy conservation plan enclosed as <b>Annexure X.</b>
14.	Opaque wall should meet prescriptive requirement as per Energy Conservation Building Code which is proposed to be mandatory for all air conditioned spaces while it is inspirational for non-air-conditioned spaces by use of appropriate thermal insulation material to fulfill requirement.	<b>Agreed.</b> Opaque wall will be made as per Energy Conservation Building Code for all air conditioned spaces while and also for non air conditioned spaces by use of appropriate thermal insulation to fulfill requirement.
15.	The approval of the competent authority shall be obtained for structural safety of the building on account of earthquake, adequacy of fire fighting equipments, etc as per National Building Code including protection measures from lightning etc. If any forest land is involved in the proposed site, clearance under Forest Conservation Act shall be obtained from the competent Authority.	<b>Agreed.</b> This is a project of Central Government, Department of Atomic Energy project. The project is conceived and detailed by in-house designers, adhering to in vogue safety and design standards. No forest land is involved in the project. Forest NOC is attached as <b>Annexure XI.</b>
16.	The project proponent as stated in the proposal shall construct 50 rainwater harvesting pits for recharging the ground	The project proponent will construct 50 rainwater harvesting pits for recharging the ground water within the project premises. Rain

वै. यस्. मय्या / Y. S. Mayya

परियोजना निदेशक / Project Director

जी सी एन ई पी, डी ए ई / GCNEP, DAE

भारत सरकार, को. ए. आर. सी. / Govt. of India B.A.R.C.

मुंबई-४०० ०८५. / Mumbai - 400 085.



	water within the project premises. Rain water harvesting pits shall be designed to make provisions for silting chamber and removal of floating matter before entering harvesting pits. Maintenance budget and persons responsible for maintenance must be provided. Care shall also be take that contaminated water do not enter any RWH pit.	water harvesting pits will be designed to make provisions for silting chamber and removal of floating matter before entering harvesting pits.
17.	The project proponent shall provide for adequate fire safety measures and equipments as required by Haryana Fire Service Act, 2009 and instructions issued by the local Authority/Directorate of fire from time to time. Further the project proponent shall take necessary permission regarding fire safety scheme/NOC from competent Authority as required.	<b>Agreed.</b> NOC from Haryana Fire Services is attached in <b>Annexure XII.</b>
18.	The project proponent shall submit assurance from the HBVNL for supply of 1700 KVA of power supply before the start of construction. In no case project will be operational solely on generators without any power supply from any external power utility.	<b>Agreed.</b> The project proponent has obtained assurance from the HBVNL for supply of 1700 KVA of power supply before the start of construction Same is enclosed as <b>Annexure XIII.</b>
19.	Detail calculation of power load and ultimate power load of the project shall be submitted to HBVNL under intimation to SEIAA Haryana before the start of construction. Provision shall be made for	<b>Agreed.</b> Total power requirement is 1700 kVA for the Institution campus and residential township project.

वै. यस. मय्या / Y. S. Mayya

परियोजना निदेशक / Project Director

सी सी एन ई पी, डी ए ई / GCNEP, DAE

भारत सरकार, पी. ए. आर. सी. / Govt. of India B.A.R.C.

मुंबई-४०० ०८५, / Mumbai - 400 085.

	electrical infrastructure in the project area.	
20.	The Project proponent shall not raise any construction in the natural land depression/Nallah/ Water course and shall ensure that the natural flow from the Nallah/ Water course is not obstructed.	<b>Agreed.</b> No construction has been raised in the natural land depression or nalah. Natural flow of water is not being obstructed due to construction activity.
21	The project proponent shall keep the plinth level of the building blocks sufficiently above the level of the approach road to the Project as per prescribed bye-laws. Levels of the other areas in the Projects shall also be kept suitably so as to avoid flooding.	<b>Agreed.</b> The plinth level of the building blocks has been made sufficiently above the level of the approach road to the project as per prescribed by-laws. Levels of the other areas in the projects are also being kept suitably so as to avoid flooding.
22.	Construction shall be carried out so that density of population does not exceed norms approved by Director General Town and Country Department Haryana.	Density of population will not exceed norms approved by Director General Town and Country Department Haryana due to the construction of project.
23.	The Project Proponent shall submit an affidavit with the declaration that ground water will not be used for construction and only treated water should be used for construction.	The project proponent is a govt. organization. Proponent has submitted an undertaking stating that they will not use Ground water for construction. Same is attached as <b>Annexure XIV.</b>
24.	The project proponent shall not cut any existing tree and project landscaping plan should be modified to include those trees in green area.	<b>Agreed.</b> There is no need to cut the trees, only small bushes clearing are being done for construction activity.
25.	The project proponent shall ensure that ECBC norms for composite climate zone are met. In Particular building envelope, HVAC service, water heating, pumping, lighting and electrical infrastructure must	<b>Agreed.</b> ECBC norms will be met. Building envelope, HVAC services, water heating, pumping, lighting electrical infrastructure will all be in energy efficient way and meet Energy conservation Building Code norms.

**वै. यस. मय्या / Y. S. Mayya**  
परियोजना निदेशक / Project Director  
जी सी एन ई पी, डी ए ई / GCNEP, DAE  
भारत सरकार, पी. ए. आर. सी / Govt. of India B.A.R.C.  
मुंबई-४०० ०८५, / Mumbai - 400 085.

	meet ECBC norms.	
26.	The project proponent shall provide 3 meter high barricade around the project area, dust screen for every floor above the ground, proper sprinkling and covering of stored material to restrict dust and air pollution during construction.	<b>Agreed.</b> Project proponent has provided site barricade and water sprinkling is being done to restrict dust and air pollution during construction. Photograph showing same is enclosed as <b>Annexure XV</b> and <b>Annexure XVI</b> respectively.
27.	The project proponent shall construct a sedimentation basin in the lower level of the project site to trap pollutant and other wastes during rains.	<b>Agreed.</b> Sedimentation basin will be constructed.
28.	The project proponent will provide proper rasta of proper width and proper strength for the project before the start of construction.	The project proponent has provided proper rasta of proper width and proper strength for the project before the start of construction. Same is enclosed as <b>Annexure XVII</b> .
29.	The project proponent shall ensure that the U value of Glass is less than 3.177 and maximum solar heat gain coefficient is 0.25 for vertical fenestration.	<b>Agreed.</b> The project, being Institution and Residential Project, will involve uses of clear & tinted glass having U-value less than 3.177.
30.	The project proponent shall adequately control construction dusts like silica dust, non-silica dust and wood dust. Such dusts shall not spread outside project premises. Project proponent shall provide respiratory protective equipments to all construction workers.	<b>Agreed.</b> Proper measures are being taken to control dust on the site, like water sprinkling, covering construction material. Site barricading is being done so that dust does not spread outside premises. Project proponent is providing provide mask and other personal protective equipment to the construction labourers.
31.	The project proponent shall provide fire control room and fire officer for building above 30 m as per national Building Code.	The height of institutional and residential building is G+2 and G+1, the height of the building will not raise above 30m.

वै. यस. मय्या / Y. S. Mayya

परियोजना निदेशक / Project Director

जी सी एन ई पी, डी ए ई / GCNEP, DAE

भारत सरकार, पी. ए. आर. सी / Govt. of India B.A.R.C.

मुंबई-४०० ०८५ / Mumbai - 400 085.

Page 7

32.	The project proponent shall obtain permission of Mines and Geology Department for excavation of soil before the start of construction.	There is no basement provided in the project. If required at any stage, we will obtain permission from concerned department.
33.	The project proponent shall seek specific prior approval from concerned local Authority/HUDA regarding provision of storm drainage and sewerage system including their integration with external services of HUDA/ Local authorities beside other required services before taking up any construction activity.	<b>Agreed.</b>
34.	The site for solid waste management plant be earmarked on the layout plan and the detailed project for setting up the solid waste management plant shall be submitted to the Authority within one month.	The site has been earmarked for solid waste management plant on the layout plan. Site Plan is attached as <b>Annexure XVIII.</b>
35.	The project proponent shall discharge excess of treated waste water/storm water in the public drainage system and shall seek permission of HUDA before the start of construction.	The project proponent will discharge excess of treated waste water/storm water in the public drainage system. Application shall be submitted to HUDA for drainage connection.
36.	The project proponent shall ensure that structural stability to withstand earthquake of magnitude 8.5 on Richter scale.	The project is being developed by Central Government, Department of Atomic Energy. The project is conceived and detailed by in-house designers, adhering to in vogue safety and design standards. All measures are being taken to ensure that building is earthquake resistant.

37.	The project proponent shall seek separate environment clearance for development of the remaining part of project as per the procedure laid down in the notification under expansion after the approval of the competent authority in Govt. of India is obtained.	Agreed.
38.	The project proponent shall be self integrated with respect to services infrastructure and shall be independent for all the purposes.	Agreed. STP treated water will be recycled within the project for flushing and horticultural purpose. Rainwater will be harvested to recharge ground water.
<b>SPECIFIC CONDITIONS : Operation Phase</b>		
a.	“Consent to operate” shall be obtained from Haryana State Pollution Control Board under Air and Water Act and a copy shall be submitted to the SEIAA, Haryana.	Agreed.
b.	The Sewage Treatment Plant (STP) shall be installed for the treatment of the sewage to the prescribed standards including odour and treated effluent will be recycled to achieve zero exit discharge. The installation of STP shall be certified by an independent expert and a report in this regard shall be submitted to the SEIAA, Haryana before the project is commissioned for operation. Tertiary treatment of waste water is mandatory. The project proponent shall remove not only Ortho-	It will be designed by specialized engineers of the Department. Tertiary treatment of waste water will be done, and the treated water will be reused in the project for horticulture and flushing.



	Phosphorus but total Phosphorus to the extent of less than 2 mg/liter. Similarly total Nitrogen level shall be less than 2 mg/liter in tertiary treated waste water. Discharge of treated sewage shall conform to the norms and standards of CPCB/HSPCB, whichever is environmentally better. Project proponent shall implement such STP technology which does not require filter backwash.	
c	Separation of the gray and black water should be done by the use of dual plumbing line. Treatment of 100 % gray water by decentralized treatment should be done ensuring that the re-circulated water should have BOD level less than 5 mg/liter and the recycled water will be used for flushing, gardening and DG set cooling etc.	<b>Agreed.</b> Dual Plumbing line will be used. The treated water from STP will be reused in the project for flushing and landscaping purposes.
d.	For disinfections of the treated waste water ultra violet radiation or Ozonization should be used.	<b>Agreed.</b> For disinfection of the treated water, ultra violet radiation will be used.
e.	Diesel power generating sets proposed as source of backup power for lifts, common area illumination and for domestic use should be of enclosed type and conform to rules made under the Environment (Protection) Act, 1986. The location of the DG sets should be in the basement as promised by the project proponent and appropriate stack height i.e., above the	<b>Agreed.</b>

 वै. यस. मय्या / Y. S. Mayya

परियोजना निदेशक / Project Director

जी सी एन ई पी, डी ए ई / GCNEP, DAE

भारत सरकार, वी. ए. आर. सी / Govt. of India B.A.R.C.

मुंबई-४०० ०८५. / Mumbai - 400 085.

	roof level as per the CPCB norms. The diesel used for DG sets should be of ultra low sulphur diesel (35 ppm sulphur), instead of low sulphur diesel.	
f.	Ambient noise level should be controlled to ensure that it does not exceed the prescribed standards both within and at the boundary of the proposed Institutional Campus and Residential Township.	Agreed.
g.	The project proponent as stated in the proposal shall maintain at least 32% for the institutional campus and 30.08% for residential township as green cover area for tree plantation especially all around the periphery of the project and on the road sides preferably with local species so as to provide protection against particulates and noise. The open spaces inside the plot should be preferably landscaped and covered with vegetation/grass, herbs and shrubs. Only locally available plant species shall be used.	Agreed.
h.	The project proponent shall strive to minimize water in irrigation of landscape by minimizing grass area, using native variety, xeriscaping and mulching, utilizing efficient irrigation system, scheduling irrigation only after checking evapo-transpiration data.	Agreed.
i.	The ground water level and its quality	Agreed.

डॉ. यस्स. मय्या / Y. S. Mayya

परियोजना निदेशक / Project Director

जी सी एन ई सी, डी ए ई / GCNEP, DAE

भारत सरकार, बी ए आर. सी / Govt. of India B.A.R.C.

मुंबई-४०० ०८५ / Mumbai - 400 085.

	should be monitored regularly in consultation with Central Ground water Authority.	
j.	A report on the energy conservation measures conforming to energy conservation norms finalize by Bureau of Energy Efficiency should be prepared incorporating details about building materials & technology; R & U factors etc. and submit to the IA Division of Environment, Haryana in three months time.	Agreed.
k.	Energy conservation measures like installation of LEDs only for lighting the areas outside the building and inside the building should be integral part of the project design and should be in place before project commissioning. Use of solar panels must be adapted to the maximum extent possible for energy conservation.	Agreed.
l.	The project proponent shall use zero ozone depleting potential material in insulation, refrigeration, air-conditioning. Project proponent shall also provide Halon free fire suppression system.	Agreed.
m.	The solid waste generated should be properly collected and segregated as per the requirement of the MSW Rules, 2000 and as amended from time to time. The bio-degradable waste should be	Agreed.



**वै. यस. मय्या / Y. S. Mayya**  
 परियोजना निदेशक / Project Director  
 जी सी एन ई पी, डी ए ई / GCNEP, DAE  
 भारत सरकार, कें. ए. अ. र. सी / Govt. of India B.A.R.C.  
 मुंबई-४०० ०८५. / Mumbai - 400 085.



	composted by vermin-composting at the site earmarked within the project area and dry/inert solid waste to be disposed off to the approved site for land filling after recovering recyclable material.	
n.	The provision of solar water heating system shall be as per the norms specified by HAREDA and shall be made operational in each building block.	<b>Agreed.</b>
o.	The traffic plan and the parking plan proposed by the project proponent should be adhered to meticulously with further scope of additional parking for future requirement. There should be no traffic congestion near the entry and exit points from the roads adjoining the proposed project site. Parking should be fully internalized and no public space should be used.	<b>Agreed.</b> Traffic cum parking plan enclosed as <b>Annexure XIX.</b>
p.	The Project shall be operationalized only when HUDA/local authority will provide domestic water supply system in the area.	<b>Agreed.</b>
q.	Operation and maintenance of STP, Solid waste management and electrical Infrastructure, pollution control measures shall be ensured.	<b>Agreed.</b>
t.	Different type of wastes should be disposed off as per the provision of municipal solid waste, biomedical waste, hazardous waste, e-waste, batteries and	<b>Agreed.</b>

वै. यस. मय्या / Y. S. Mayya

परियोजना निदेशक / Project Director

जी सी एन ई पी, डी ए ई / GCNEP, DAE

भारत सरकार, वी. ए. आर. सी / Govt of India B.A.R.C.

मुंबई-४०० ०८५. / Mumbai - 400 085.

	plastic rules made under Environment Protection Act, 1986. Particularly E-waste and Battery waste shall be disposed of as per existing E-waste Management Rules 2011 and Batteries Management Rules 2001. The project proponent shall maintain a collection center for E-waste and it shall be disposed of to only registered and authorized dismantler / recycler as per existing E-waste Management Rules 2011.	
s.	Standards for discharge of environmental pollutants as enshrined in various schedule of Rule 3 of Environment Protection Rule, 1986 shall be strictly complied with.	<b>Agreed.</b>
t.	The project proponent shall make provision for guard pond and other provision for safety against failure in the operation of wastewater treatment facilities. The Project proponent shall also identify acceptable outfall for treated effluent.	<b>Agreed.</b> During failure of STP, automatic valves will be open and water will be drained out in sewerage system. Project proponent will provide guard pond.
u.	The project proponent shall ensure that the stack height of DG sets is as per the CPCB guide lines and also ensure that the emission standards of noise and air are within the CPCB latest prescribed limits. Noise and Emission level of DG sets greater than 800 KVA shall be as per CPCB latest standards	<b>Agreed.</b> DG Sets will have adequate stack height of 6m above maximum height of the building, and it will be ensured that emission standard of noise and air are within limits. No high capacity DG sets are being used in the project.



वै. यस. मय्या / Y. S. Mayya

परियोजना निदेशक / Project Director

जी सी एन ई पी, डी ए ई / GCNEP, DAE

भारत सरकार, वी. ए. आर. सी / Govt. of India B.A.R.C.

मुंबई-४०० ०८५. / Mumbai - 400 085.

	for high capacity DG sets.	
v.	All electric supply exceeding 100 amp, 3 phase shall maintain the power factor between 0.98 lag to 1 at the point of connection.	Agreed.
w.	The project proponent shall minimize heat island effect through shading and reflective or pervious surface instead of hard surface.	Agreed.
x.	The project proponent shall not use fresh water for HVAC and DG cooling. Air based HVAC system should be adopted and only treated water shall be used by project proponent for cooling, if it is at all needed. The Project Proponent shall also use evaporative cooling technology and double stage cooling system for HVAC in order to reduce water consumption. Further temperature, relative humidity during summer and winter seasons should be kept at optimal level. Variable speed drive, best Co-efficient of Performance (CoP), as well as optimal Integrated Point Load Value and minimum outside fresh air supply may be resorted for conservation of power and water. Coil type cooling DG Sets shall be used for saving cooling water consumption for water cooled DG Sets.	Agreed.
y.	The project proponent shall ensure that	Agreed.

**वै. यस. मय्या / Y. S. Mayya**  
 परियोजना निदेशक / Project Director  
 जी सी एन ई पी, डी ए ई / GCNEP, DAE  
 भारत सरकार, पी. ए. आर. सी. / Govt. of India B.A.R.C.  
 मुंबई-४०० ०८५ / Mumbai - 400 085.

	the transformer is constructed with high quality grain oriented, low loss silicon steel and virgin electrolyte grade copper. The project proponent shall obtain manufacturer's certificate also for that.	
z.	Water supply shall be metered among different users and different utilities	<b>Agreed.</b>
aa.	The project proponent shall ensure that exit velocity from the stack should be sufficiently high. Stack shall be designed in such a way that there is no stack down-wash under any meteorological conditions.	<b>Agreed.</b>
ab.	The project proponent shall provide water sprinkling system in the project area to suppress the dust in addition to the already suggested mitigation measures in the Air Environment Chapter of EMP.	<b>Agreed.</b>
ac.	The project proponent shall provide additional green area on terrace and roof top.	<b>Agreed.</b>
ad.	The project proponent shall ensure proper Air Ventilation and light system in the basements area for comfortable living of human being and shall ensure that number of Air Changes per hour/ (ACH) in basement never falls below 15. In case of emergency capacity for increasing ACH to the extent of 30 must be provided by the project	<b>Agreed.</b> The project proponent will ensure proper Air Ventilation and light system in the basements area for comfortable living of human being and will ensure that number of Air Changes per hour/ (ACH) in basement never falls below 15.

  
 वै. यस. मय्या / Y. S. Mayya  
 परियोजना निदेशक / Project Director  
 जी सी एन ई पी, डी ए ई / GCNEP, DAE  
 भारत सरकार, पी. ए. आर. सी. / Govt. of India B.A.R.C.  
 मुंबई-४०० ०८५. / Mumbai - 400 085.

	proponent.	
ae.	The project proponent shall install solar panel for energy conservation.	<b>Agreed.</b>
<b>PART-B GENERAL CONDITIONS</b>		
I	The project proponent shall ensure the commitments made in Form 1, Form 1A, EIA/EMP and other documents submitted to the SEIAA for the protection of environment and proposed environmental safeguards are complied with in letter and spirit. In case of contradiction between two or more documents on any point, the most environmentally friendly commitment on the point shall be taken as commitment by project proponent.	<b>Agreed.</b> The environmental safeguards contained in the EIA/EMP Report are being implemented in letter and spirit.
II	The project proponent shall also submit six monthly reports on the status of compliance of the stipulated EC conditions including results of monitored data (both in hard copy as well as by email) to the northern Regional Office of MoEF, the respective Zonal Office of CPCB, HSPCB and SEIAA, Haryana.	<b>Agreed.</b> Hard and soft copy of Six monthly compliance reports will be submitted in the month of July & January every year.
III	STP outlet after stabilization and stack emission shall be monitored monthly. Other environmental parameters and green belt shall be monitored on quarterly basis. After every 3months, the project proponent shall conduct environmental audit and shall take corrective measures, if required, without delay.	<b>Agreed.</b>

वै. यस. मय्या / Y. S. Mayya

परियोजना निदेशक / Project Director

जी सी एन ई पी डी ए ई / GCNEP, DAE

भारत सरकार, वी. ए. आर. सी / Govt. of India B.A.R.C.

मुंबई-४०० ०८५ / Mumbai - 400 085.

IV	The SEIAA, Haryana reserves the right to add additional safeguards measures subsequently, if found necessary. Environmental Clearance granted will be revoked if it is found that false information has been given for getting approval of this project. SEIAA reserves the right to revoke the clearance if conditions stipulated are not implemented to the satisfaction of SEIAA/MoEF	Agreed.
V	The project proponent shall not violate any judicial orders/pronouncement issued by any court/tribunal.	Agreed.
VI	All other statutory clearances such as the approvals for storage of diesel from chief Controller of Explosives, Fire Department, Civil Aviation Department, Forest conservation Act, 1980 and Wildlife (Protection) Act, 1972, PLPA, 1900 etc. shall be obtained as, applicable by Project proponents from the respective authorities prior to construction of the project.	Agreed.
VII	The project proponent should inform the public that the project has been accorded Environment Clearance by the SEIAA and copies of the clearance letter are available with the Haryana State Pollution Control Board & SEIAA. This should be advertised within 7 days from the date of issue of clearance letter at least in two	Agreed. Advertisement copy is enclosed as Annexure XX.

	local newspapers that are widely circulated in the region and the copy of the same be forwarded to SEIAA Haryana. A copy of Environment Clearance collections shall also be put on project proponent's website for public awareness.	
VIII	Under the provisions of Environment (Protection) Act, 1986, legal action shall be initiated against the project proponent if it was found that construction of the project has been started without obtaining Environmental Clearance.	<b>Agreed.</b> Construction has been started only after obtaining Environment Clearance from State Environment Impact Assessment Authority, Haryana vide letter no. SEIAA/HR/2014/1385 Dated 07.11.2014. Copy of EC Letter is enclosed as <b>Annexure XXI.</b>
IX	Any appeal against this Environmental Clearance shall lie with the National Green Tribunal, if preferred within a period of 30 days as prescribed under Section 16 of the National Green Tribunal Act, 2010.	<b>Agreed.</b>
X	The project proponent shall put in place Corporate Environment policy as mentioned in MoEF, GoI OM No. J-11013/41/2006-1A II(I) dated 26.4.2012 within 3 months period. Latest corporate Environment policy should be submitted to SEIAA within 3 months of issuance of this letter.	The project proponent being a Department of Government of India, so Corporate Environment Policy is not applicable. Instead under Entry Point Activities, the proponent has earmarked Rs. 10.0 Crore for development in neighborhood area which includes some of the specific project on environmental protection like (i) Bhindawas (Jhajjar) Bird Sanctuary, (ii) Desalination plant for village Jasaur-Kheri. The other activities includes Construction of Girls Degree College in village Jasaur Kheri

वै. यस. मय्या / Y. S. Mayya

Page 19

परियोजना निदेशक / Project Director  
 जी सी एन ई पी, डी ए ई / GCNEP, DAE  
 भारत सरकार, वी. ए. आर. सी / Govt. of India B.A.R.C.  
 मुंबई-४०० ०८५ / Mumbai - 400 085.

		(GCNEP project site village) The proponent has committed a onetime grant of Rs 150 lakh for this activity and has already contributed Rs. 50 Lakh.
XI	The fund ear-marked for environment protection measures should be kept in separate account and should not be diverted for other purposes and year wise expenditure shall be reported to the SEIAA/RO MoEF GOI under rules prescribed for Environment Audit.	Agreed.
XII.	The project proponent shall ensure the compliance of Forest Department, Haryana Notification no. S.O.121/PA2/1900/S.4/97 dated 28.11.1997.	Agreed.
XIII.	The Project Proponent shall ensure that no vehicle during construction/operation phase enter the project premises without valid 'Pollution Under Control' certificate from competent Authority.	Agreed.
XIV	The project proponent shall seek fresh Environmental clearance if at any stage there is change in the planning of the proposed project.	Agreed.
XV	Nodal Officer (Project Director) nominated by GCNEP shall be responsible for implementation of all conditions of Environmental Clearance letter.	Agreed.

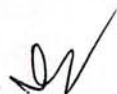

वै. यश. मय्या / Y. S. Mayya  
 परियोजना निदेशक / Project Director  
 जी सी एन ई पी, डी ए ई / GCNEP, DAE  
 भारत सरकार, वी. ए. आर. सी. / Govt. of India B.A.R.C.  
 मुंबई-४०० ०८५. / Mumbai - 400 085.



XVI	The proponent shall upload the status of compliance of the stipulated EC conditions, including results of monitored data on their website and shall update the same periodically. It shall simultaneously be sent to the Regional Office of MoEF, the respective Zonal Office of CPCB and the SPCB. The criteria pollutant levels namely; PM <sub>2.5</sub> , PM <sub>10</sub> , SO <sub>x</sub> , NO <sub>x</sub> , Ozone, Lead, CO, Benzene, Ammonia, Benzopyrine, arsenic and Nickel. (Ambient levels as well as stack emissions) or critical sectoral parameters, indicated for the project shall be monitored and displayed at a convenient location near the main gate of the company in the public domain.	Agreed.
XVII	The environmental statement for each financial year ending 31 <sup>st</sup> March in Form-V as is mandated to be submitted by the project proponent to the HSPCB Panchkula as prescribed under the Environment (Protection) Rules, 1986, as amended subsequently, shall also be put on the website of the company along with the status of compliance of the EC conditions and shall also be sent to the respective Regional Offices of MoEF by e-mail.	Agreed.
XVIII	The project proponent shall conduct environment audit at every three months	Agreed.



Interval and thereafter corrected measures shall be taken without any delay. Details of environmental audit and corrective measures shall be submitted in the monitoring report.	
--	--

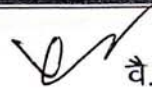

**वै. यस. मय्या / Y. S. Mayya**  
परियोजना निदेशक / Project Director  
जी सी एन ई पी, डी ए ई / GCNEP, DAE  
भारत सरकार, बी. ए. आर. सी. / Govt. of India B.A.R.C.  
मुंबई-४०० ०८५. / Mumbai - 400 085.



**HARYANA STATE POLLUTION CONTROL BOARD  
C-11, SECTOR-6, PANCHKULA**

Website – [www.hspcb.gov.in](http://www.hspcb.gov.in) E-Mail - [hspcb.pkl@sifymail.com](mailto:hspcb.pkl@sifymail.com)

Telephone No. – 0172-2577870-73

No. HSPCB/Consent/ : 2821215JHACTE1432687

Dated:27/02/2015

To

M/s : Global Centre for Nuclear Energy Partnership (Institute & Township)  
Vill. Jasuar Kheri & Kheri Jasaur, Tel Bahadurgarh  
**JHAJJAR**  
124505

**Sub. : Issue of Consent to Establish from pollution angle .**

Please refer to your Consent to Establish application received in this office on the subject noted above. Under the Authority of the Haryana State Pollution Control Board vide its agenda Item No. 47.8 dated 28.04.83 sanction to the issue of "Consent to Establish" with respect to pollution control of Water and Air is hereby accorded to the unit Global Centre for Nuclear Energy Partnership (Institute & Township), for manufacturing of / Unit is a **proposed institutional campus and residential township with proposing the scheme of STP of 106.4 KLD for the treatment of D.E.** with the following terms and conditions:-

1. The industry has declared that the quantity of effluent shall be 106.4 KL/Day i.e 0KL/Day for Trade Effluent, 0 KL/Day for Cooling, 106.4 KL/Day for Domestic and the same should not exceed .
2. The above "Consent to Establish" is valid for 24 months from the date of its issue to be extended for another one year at the discretion of the Board or till the time the unit starts its trial production whichever is earlier. The unit will have to set up the plant and obtain consent during this period.
3. The officer/official of the Board shall have the right to access and inspection of the industry in connection with the various processes and the treatment facilities being provided simultaneously with the construction of building/machinery. The effluent should conform the effluent standards as applicable
4. That necessary arrangement shall be made by the industry for the control of Air Pollution before commissioning the plant. The emitted pollutants will meet the emission and other standards as laid/will be prescribed by the Board from time to time.
5. The applicant will obtain consent under section 25/26 of the Water (Prevention & Control of Pollution) Act, 1974 and under section 21/22 of the Air (Prevention & Control of Pollution) Act, 1981 as amended to-date-even before starting trial production
6. The above Consent to Establish is further subject to the conditions that the unit complies with all the laws/rules/decisions and competent directions of the Board/Government and its functionaries in all respects before commissioning of the operation and during its actual working strictly.
7. No in-process or post-process objectionable emission or the effluent will be allowed, if the scheme furnished by the unit turns out to be defective in any actual experience
8. The Electricity Department will give only temporary connection and permanent connection to the unit will be given after verifying the consent granted by the Board, both under Water Act and Air Act.

परियोजना निदेशक / Project Director

जी सी एन ई पी, डी ए ई / GCNEP, DAE

भारत सरकार, पी. ए. आर. सी / Govt. of India B.A.R.C.

मंत्रालय, अणु ऊर्जा, मुंबई 400 085

9. Unit will raise the stack height of DG Set/Boiler as per Board's norms.
10. Unit will maintain proper logbook of Water meter/sub meter before/after commissioning.
11. That in the case of an industry or any other process the activity is located in an area approved and that in case the activity is sited in an residential or institutional or commercial or agricultural area, the necessary permission for siting such industry and process in an residential or institutional or commercial or agricultural area or controlled area under Town and Country Planning laws CLU or Municipal laws has to be obtained from the competent Authority in law permitting this deviation and be submitted in original with the request for consent to operate.
12. That there is no discharge directly or indirectly from the unit or the process into any interstate river or Yamuna River or River Ghaggar.
13. That the industry or the unit concerned is not sited within any prohibited distances according to the Environmental Laws and Rules, Notification, Orders and Policies of Central Pollution control Board and Haryana State Pollution Control Board.
14. That of the unit is discharging its sewage or trade effluent into the public sewer meant to receive trade effluent from industries etc. then the permission of the Competent Authority owing and operating such public sewer giving permission letter to his unit shall be submitted at time of consent to operate.
15. That if at any time, there is adverse report from any adjoining neighbor or any other aggrieved party or Municipal Committee or Zila Parishad or any other public body against the unit's pollution; the Consent to Establish so granted shall be revoked.
16. That all the financial dues required under the rules and policies of the Board have been deposited in full by the unit for this Consent to Establish.
17. In case of change of name from previous Consent to Establish granted, fresh Consent to Establish fee shall be levied.
18. Industry should adopt water conservation measures to ensure minimum consumption of water in their Process. Ground water based proposals of new industries should get clearance from Central Ground Water Authority for scientific development of previous resource.
19. That the unit will take all other clearances from concerned agencies, whenever required.
20. That the unit will not change its process without the prior permission of the Board.
21. That the Consent to Establish so granted will be invalid, if the unit falls in Aravali Area or non conforming area.
22. That the unit will comply with the Hazardous Waste Management Rules and will also make the non-leachate pit for storage of Hazardous waste and will undertake not to dispose off the same except for pit in their own premises or with the authorized disposal authority.
23. That the unit will submit an undertaking that it will comply with all the specific and general conditions as imposed in the above Consent to Establish within 30 days failing which Consent to Establish will be revoked.
24. That unit will obtain EIA from MoEF, if required at any stage.
25. In case of unit does not comply with the above conditions within the stipulated period, Consent to Establish will be revoked.

#### Specific Conditions

वै. यस. मय्या / Y. S. Mayya  
 परियोजना निदेशक / Project Director  
 जी सी एन ई पी, डी ए ई / GCNEP, DAE  
 भारत सरकार, वी. ए. आर. सी / Govt. of India B.A.R.C.  
 मुंबई-४०० ०८५. / Mumbai - 400 085.



- 1 Green belt of adequate width shall be provided by the unit.
- 2 Unit will not discharge any trade effluent & will not use any source of emissions
- 3 Unit shall obtain trial consent to operate before start of production
- 4 The unit shall dispose plastic waste only to authorised agency for disposal of plastic waste by any state pollution control board

**Other Conditions :**

**unit will comply with the conditions of Env Clearance granted**

*Senior Scientist, HQ  
For and on behalf of chairman  
Haryana State Pollution Control Board*

---It is system generated certificate no signature is required---

वै. यस्. मय्या / Y. S. Mayya

परियोजना निदेशक / Project Director

जे. सी. एन. ई. पी. डी. ए. ई. / GCNEP, DAE

भारत सरकार की. ए. आर. सी. / Govt. of India B.A.R.C.

मुंबई-४०० ०८५ / Mumbai - 400 085.



## Annexure II: First Aid Room

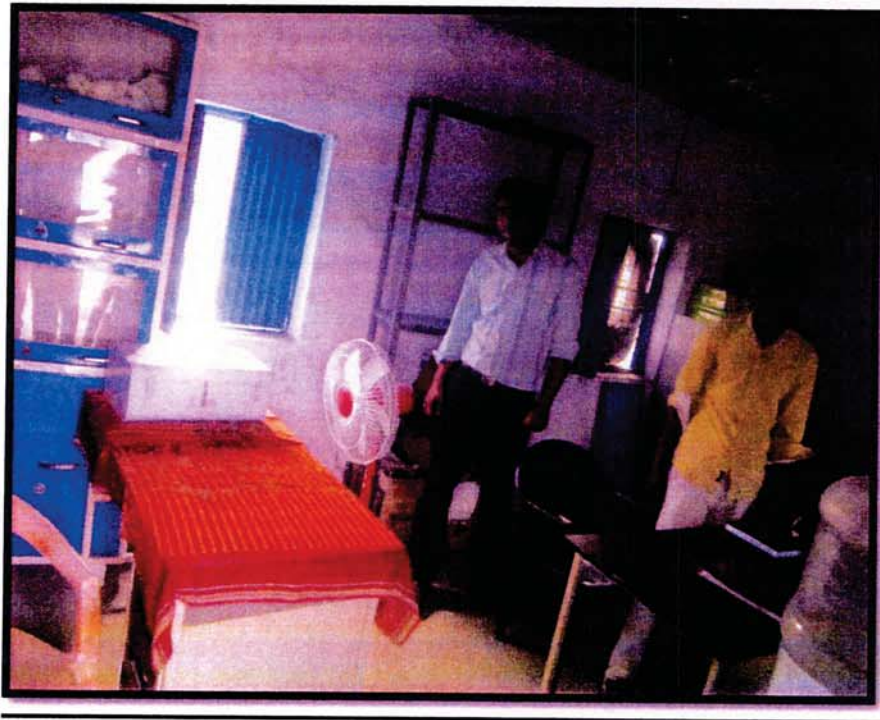
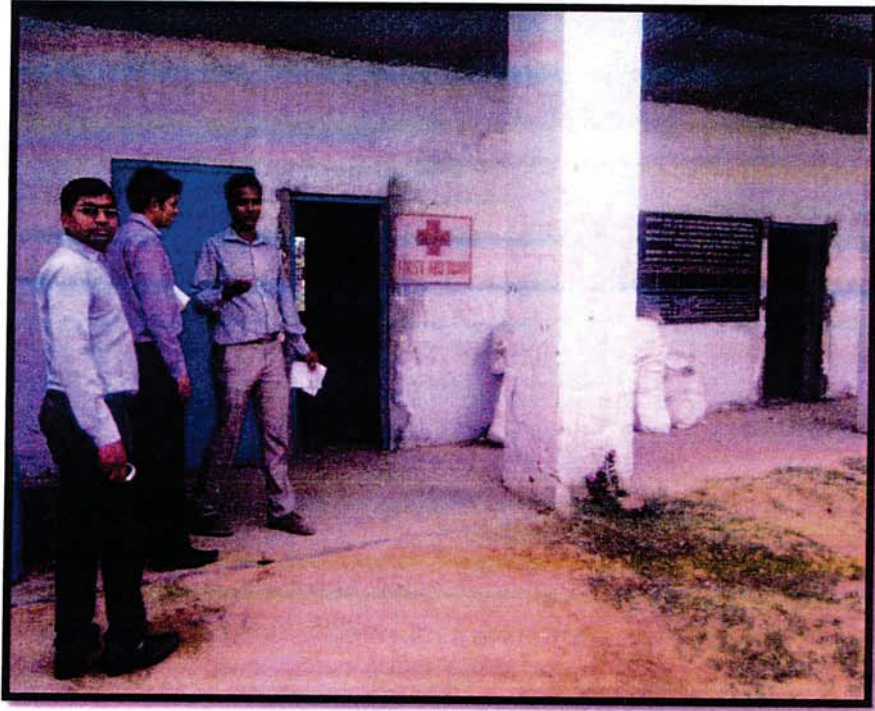

वै. यस. मय्या / Y. S. Mayya  
परियोजना निदेशक / Project Director  
डी.सी.एन.डी.सी. डी.ए.ई. / GCNEP, DAE  
भारत सरकार, नई दिल्ली / Govt. of India B.A.R.C.  
मुंबई-४०० ०८५ / Mumbai - 400 085.

✓





## Annexure III



**Drinking Water**

**वै. यस. मय्या / Y. S. Mayya**

परियोजना निदेशक / Project Director

जी सी एन ई पी, डी ए ई / GCNEP, DAE

भारत सरकार, नई दिल्ली, Govt. of India B.A.R.C.

मुंबई-४०० ०८५ / Mumbai - 400 085.

✓



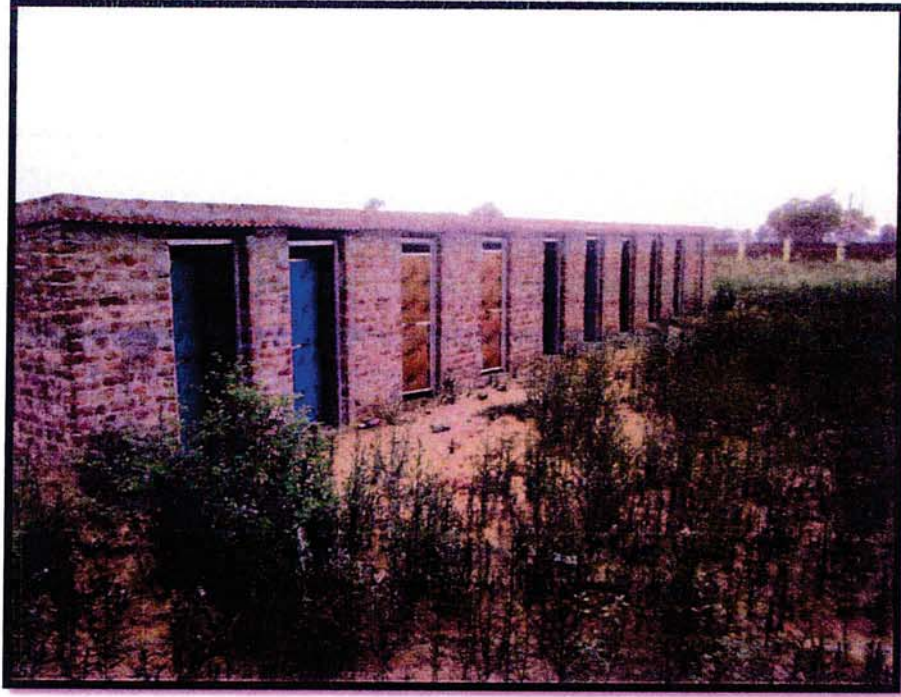

**Toilet Facilities**



**Septic Tank**

वै. यसा. मय्या / Y. S. Mayya  
परियोजना निदेशक / Project Director  
ऑ. सी. एन. डी. पी. डी. ए. डी. / ICNED, DAE  
भारत सरकार, ए. आर. सी. / Govt. of India BARC  
मुंबई-४०० ०८५ / Mumbai - 400 085.



## SOLID WASTE MANAGEMENT PLAN

Solid waste would be generated both during the construction as well as during the operation phase. The solid waste expected to be generated during the construction phase will comprise of excavated materials, used bags, bricks, concrete, MS rods, tiles, wood etc. The following steps are proposed to be followed for the management solid waste:

- Construction yards are proposed for storage of construction materials.
- The excavated material such as topsoil and stones will be stacked for reuse during later stages of construction
- Excavated top soil will be stored in temporary constructed soil bank and will be reused for landscaping of the Residential Group Housing Colony project.
- Remaining soil shall be utilized for refilling / road work / rising of site level at locations/ selling to outside agency for construction of roads etc.

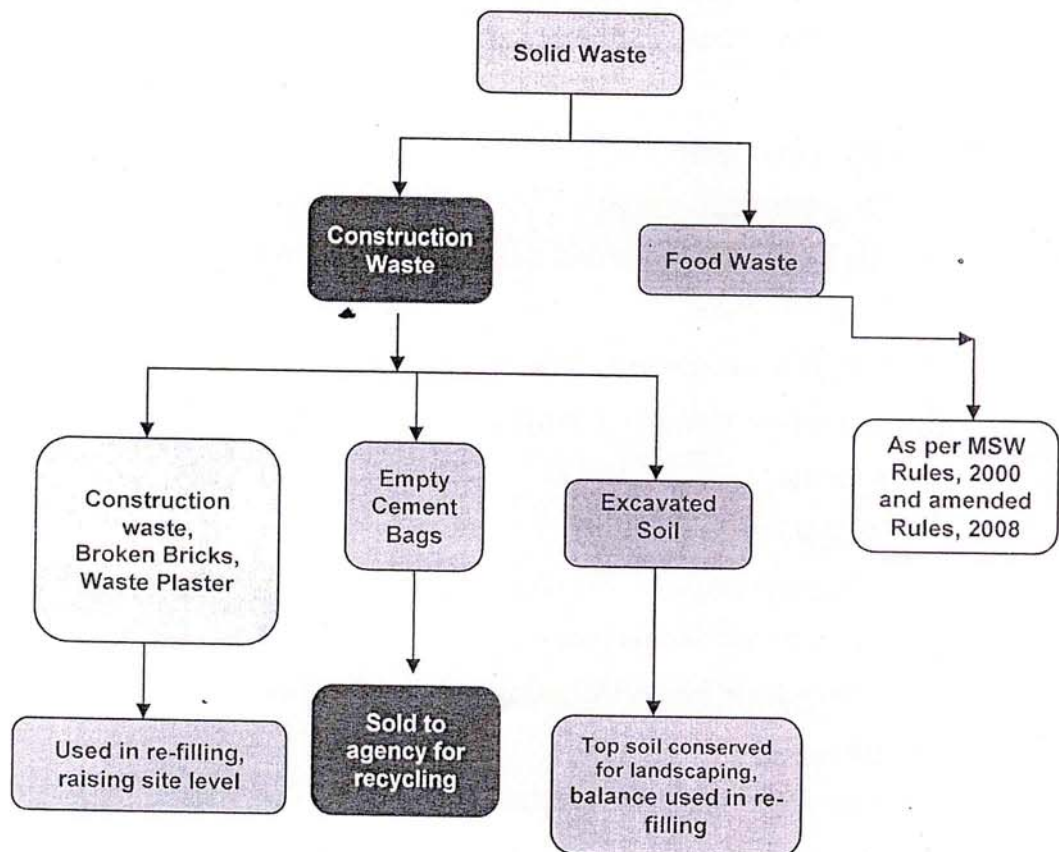

**Figure 1: Solid Waste Management Scheme (Construction Phase)**

During the operation phase, waste will comprise domestic as well as agricultural waste. The solid waste generated from the project shall be mainly domestic waste and estimated quantity

of the waste shall be approx. 1530 kg per day (@ 0.5 kg per capita per day for residents and students, @ 0.15 kg per capita per day for the visitor, 0.25 kg per capita per day for the staff members and landscape wastes @ 15 kg/acre/day). Following arrangements will be made at the site in accordance to Municipal Solid Wastes (Management and Handling) Rules, 2000 and amended Rules, 2008.

❖ **Collection and Segregation of waste**

1. A door to door collection system will be provided for collection of domestic waste in colored bins from household units.
2. The local vendors will be hired to provide separate colored bins for dry recyclables and Bio-Degradable waste.
3. For commercial waste collection, adequate number of colored bins (Green and Blue & dark grey bins– separate for Bio-degradable and Non Bio-degradable) are proposed to be provided at the strategic locations of the commercial area.
4. Litter bin will also be provided in open areas like parks etc.

❖ **Treatment of waste**

• Bio-Degradable wastes

1. Bio-degradable waste will be subjected to vermicomposting and the compost will be used as manure.
2. STP sludge is proposed to be used for horticultural purposes as manure.
3. Horticultural Waste is proposed to be composted and will be used for gardening purposes.

• Recyclable wastes

- i. Grass Recycling – The cropped grass will be spread on the green area. It will act as manure after decomposition.
- ii. Recyclable wastes like paper, plastic, metals etc. will be sold off to recyclables.

❖ **Disposal**

Recyclable and non-recyclable wastes will be disposed through Govt. approved agency. Hence, the Municipal Solid Waste Management will be conducted as per the guidelines of Municipal Solid Wastes (Management and Handling) Rules, 2000 and amended Rules, 2008. A Solid waste management Scheme is depicted in the following figure for the Residential Group Housing Colony Project.

❖ **यस. मय्या / Y. S. Mayya**  
परियोजना निदेशक / Project Director  
ग. व. ए. ई. पी. डी. ए. ई. / G.C.N.E.P, DAE  
भारत सरकार, पी. ए. आर. सी. / Govt. of India B.A.R.C.  
मुंबई-४०० ०८५, Mumbai - 400 085.

✓

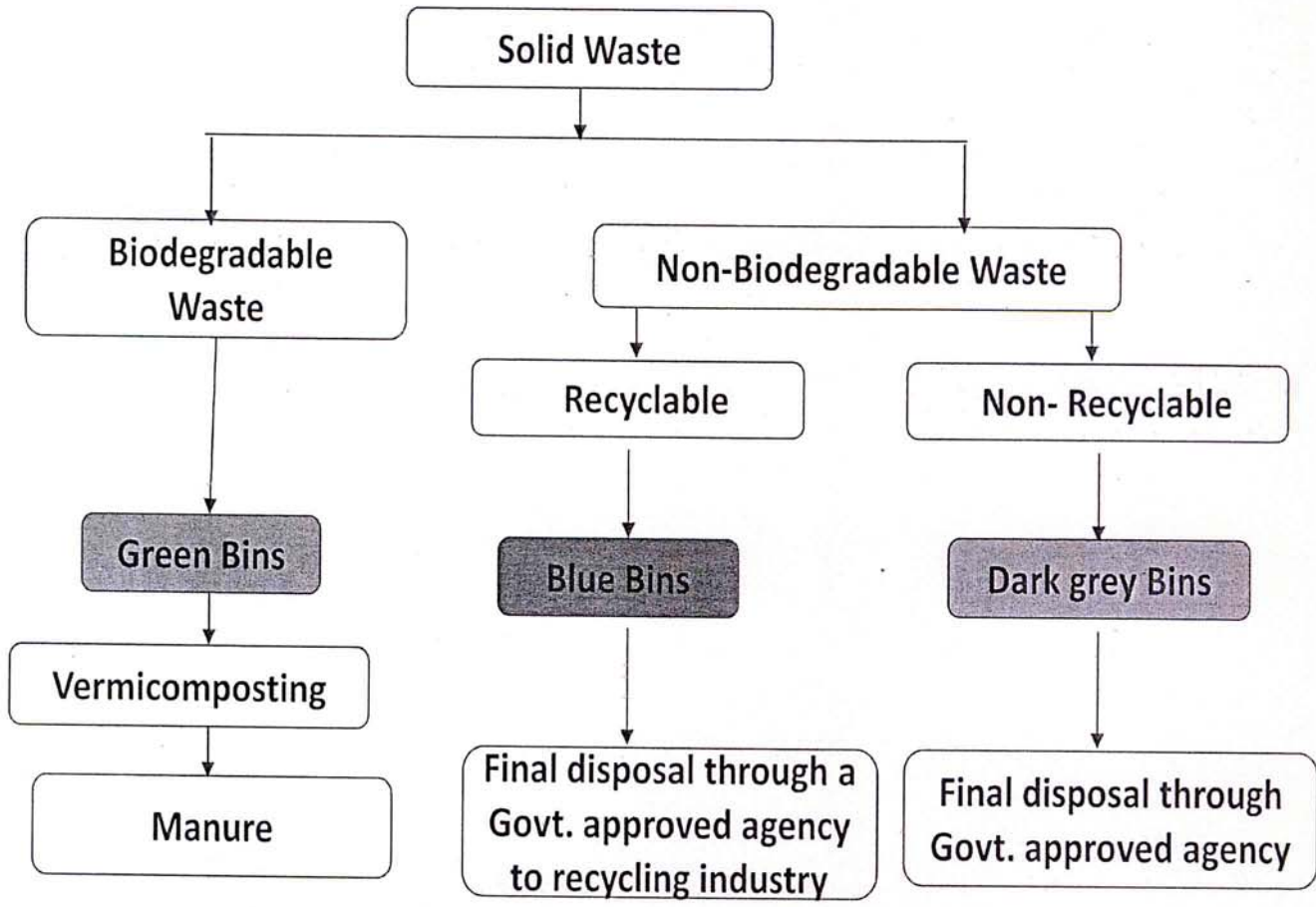

**Figure 2: Solid Waste Management Scheme (Operation Phase)**

चै. यसा. मय्या / Y. S. Mayya  
 परियोजना निदेशक / Project Director  
 जी सी एन ई पी, डी ए ई / GCNEP, DAE  
 भारत सरकार, भी. ए. आर. सी / Govt. of India B.A.R.C.  
 मुंबई-४०० ०८५ / Mumbai - 400 085. 30





**ANNEXURE V: PHOTOGRAPH SHOWING STORAGE OF TOP SOIL**



वै. यस. मय्या / Y. S. Mayya

परियोजना निदेशक / Project Director

जी सी एन ई पी डी ए ई / GCNEP, DAE

भारत सरकार, पी. ए. आर. सी / Govt. of India B.A.R.C.

मुंबई - ४०० ०८५ / Mumbai - 400 085.



ANNEXURE VI: COVERED CONSTRUCTION MATERIAL

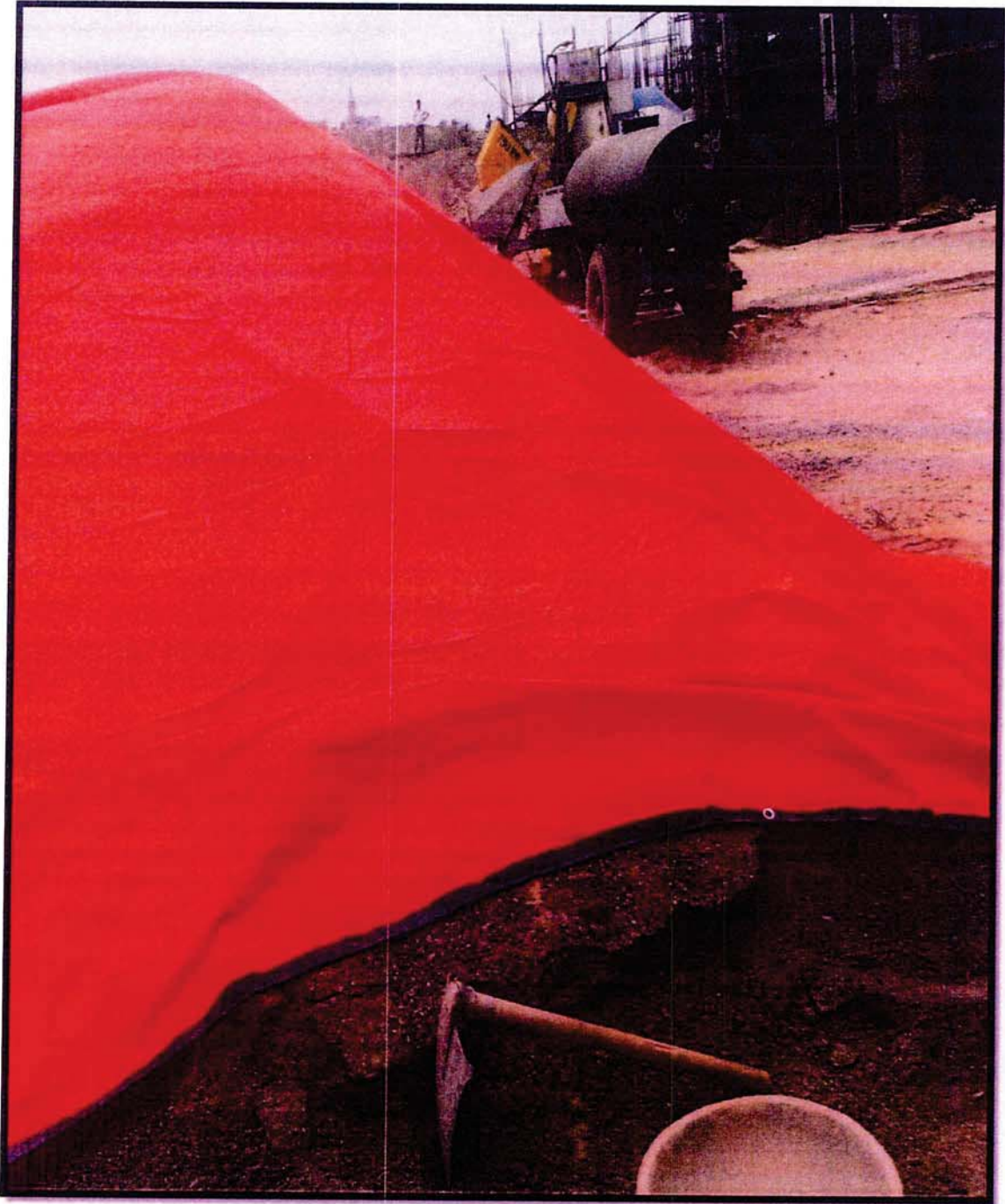

डॉ. यश. मय्या / Y. S. Mayya  
परियोजना निदेशक / Project Director  
जी सी एन ई पी, डी ए ई / GCNEP, DAE  
भारत सरकार, बी. ए. आर. सी / Govt. of India B.A.R.C.  
मुम्बई-४०० ०८५ / Mumbai - 400 085.





# GRC INDIA TRAINING & ANALYTICAL LABORATOR

(A unit of Grass Roots Research & Creation India (P) Ltd. Accredited by QCI/NABET)

An ISO 9001: 2008, ISO 14001 : 2004 & ISO 18001 : 2007 Certified Co.

(Recognised by Ministry of Environment & Forest (Govt. of India) under the Environment Protection Act, 1986  
NABL Accredited Laboratory (Dept. of Science & Technology, GoI) Chemical: T-2195, Biological: T-219

Head Office: F-375, Sec-63, NOIDA – 201 301,

Ph. No.: 0120 – 4044630, 4044660, 4323120, Fax: 0120 – 2406519

Website: <http://www.grc-india.com>, E-mail : [info@grc-india.com](mailto:info@grc-india.com), [lab@grc-india.com](mailto:lab@grc-india.com)

GRC India

## Test Report

Report Code: N20150320-007

Issue Date: 20.03.2015

Issued To : Institutional Campus & Residential Township,  
Jhajjar (H.R)

Data Received on: 19.03.2015

Sample Description: Ambient Noise

## RESULTS

### Ambient Noise Level

#### MONITORING DETAILS

Date of Monitoring	: 18.03.2015
Monitoring Done by	: Mr. Surendra
Monitoring Protocol	: GRC/LAB/STP/NOISE/01
Weather Condition	: Clear Sky
Monitoring Duration	: 24 Hours

S. No.	LOCATION	ZONE	Limit for As Per E(P)A,1986 ;Leq, dB (A)		Observed Value Leq, dB (A)	
			Day Time*	Night Time**	Day Time*	Night Time**
1	Project Site	Residential Area	55	45	56.8	44.1
	* Day Time	6.00 a.m. to 10.00 p.m				
	**Night Time	10.00 p.m. to 6.00 a.m.				

**\*\*End of Report\*\***

Authorized Signatory  
 (Seal & Signature)

- Note: 1. The results indicated only refer to the tested samples and listed parameters and do not endorse any product  
 2. This certificate shall not be reproduced wholly or in part without prior written consent of the laboratory.  
 3. This certificate shall not be used in any advertising media or as evidence in the court of Law without prior written consent of the laboratory  
 4. The samples received shall be destroyed after 30 days from the date of issue of the certificate unless specified otherwise and sample for biological testing will be destroyed after one week of testing.

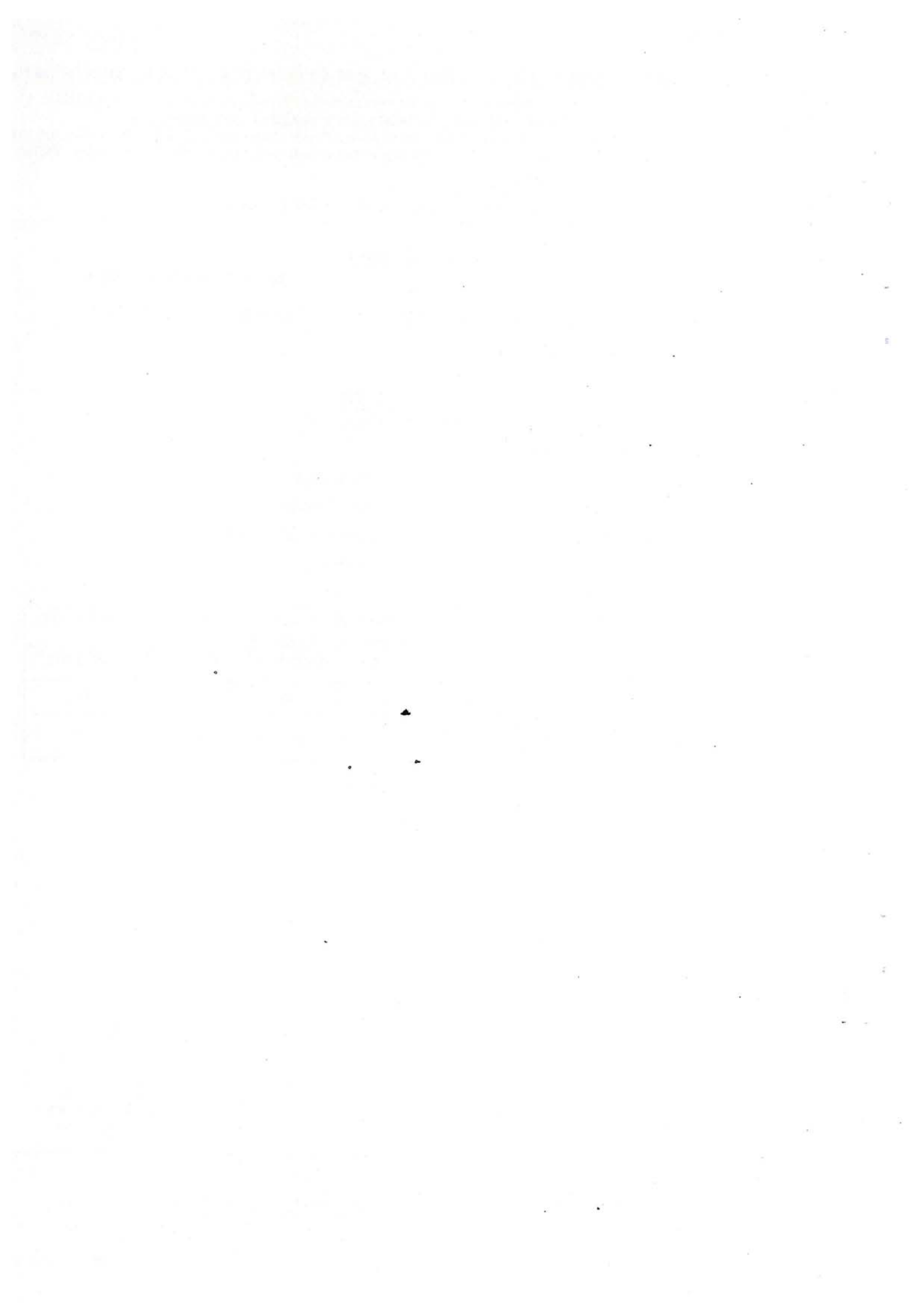



# GRC INDIA TRAINING & ANALYTICAL LABORATORY

(A unit of Grass Roots Research & Creation India (P) Ltd. Accredited by QCI/NABET)

An ISO 9001: 2008, ISO 14001 : 2004 & ISO 18001 : 2007 Certified Co.

(Recognised by Ministry of Environment & Forest (Govt. of India) under the Environment Protection Act, 1986  
NABL Accredited Laboratory (Dept. of Science & Technology, GoI) Chemical: T-2195, Biological: T-2196

Head Office: F-375, Sec-63, NOIDA – 201 301,

Ph. No.: 0120 – 4044630, 4044660, 4323120, Fax: 0120 – 2406519

Website: <http://www.grc-india.com> , E-mail : [info@grc-india.com](mailto:info@grc-india.com) , [lab@grc-india.com](mailto:lab@grc-india.com)

GRC India

## Test Report

Report Code: S20150319-045

Issue Date: 19.03.2015

Issued To: Institutional Campus & Residential Township,  
Jhajjar (H.R)

Sample Received on: 06.03.2015

Analysis Duration: 07.03.2015 to 18.03.2015

Sample Description: Soil

## RESULTS

### Soil Quality Analysis

#### SAMPLING DETAILS

Date of Sampling

: 06.03.2015

Sampling Location

: Project Site

Sample Collected by

: Mr. Surendra

Sampling Protocol

: GRC/LAB/STP/SOIL/01

Weather Condition

: Clear Sky

Sample Quantity

: 5 kg

Sample Packing & Marking

: Zip Polybag; ICR/MAR/SQ1

S. No.	Parameters	Units	Results	Test Method
1	Texture	-	Sandy Loam	IS: 2720 (part-4), 1985 (Reaff:2006)
	Sand	%	59.6	
	Silt	%	21.3	
	Clay	%	19.1	
2	pH (1:2 Suspension)		7.53	IS: 2720 (part-26),1987 (Reaff:2007)
3	Electrical Conductivity (1:2)	µmhos/cm	536	IS: 14767(2002)
4	Cation exchange capacity	meq/100 gm	13.9	IS : 2720 (Part-24)-1976(Reaff.2005)
5	Exchangeable Potassium	meq/100 gm	0.29	GRC/LAB/STP/SOIL/07
6	Exchangeable Sodium	meq/100 gm	0.58	GRC/LAB/STP/SOIL /06
7	Exchangeable Calcium	meq/100 gm	9.31	GRC/LAB/STP/SOIL/ 08
8	Exchangeable Magnesium	meq/100 gm	3.71	GRC/LAB/STP/SOIL/ 08
9	Sodium Absorption Ratio	-	0.72	GRC/LAB/STP/SOIL/20
10	Water Holding Capacity	%	27.3	GRC/LAB/STP/SOIL/13
11	Porosity	%	37.6	GRC/LAB/STP/SOIL/19
12	Permeability	cm/hrs	2.0	IS : 2720 (Part-17)-1986(Reaff.2002)
13	Total kjehdahl Nitrogen	%	0.049	GRC/LAB/STP/SOIL/18
14	Phosphorus(Olsen's)	mg/kg	6.8	GRC/LAB/STP/SOIL/10
15	Organic Matter	%	0.35	IS : 2720 (Part-22)-1972(Reaff.2006)

\*\*End of Report\*\*

Authorized Signatory  
(Seal & Signature)

- Note: 1. The results indicated only refer to the tested samples and listed parameters and do not endorse any product  
2. This certificate shall not be reproduced wholly or in part without prior written consent of the laboratory.  
3. This certificate shall not be used in any advertising media or as evidence in the court of Law without prior written consent of the laboratory  
4. The samples received shall be destroyed after 30 days from the date of issue of the certificate unless specified otherwise and sample for biological testing will be destroyed after one week of testing.

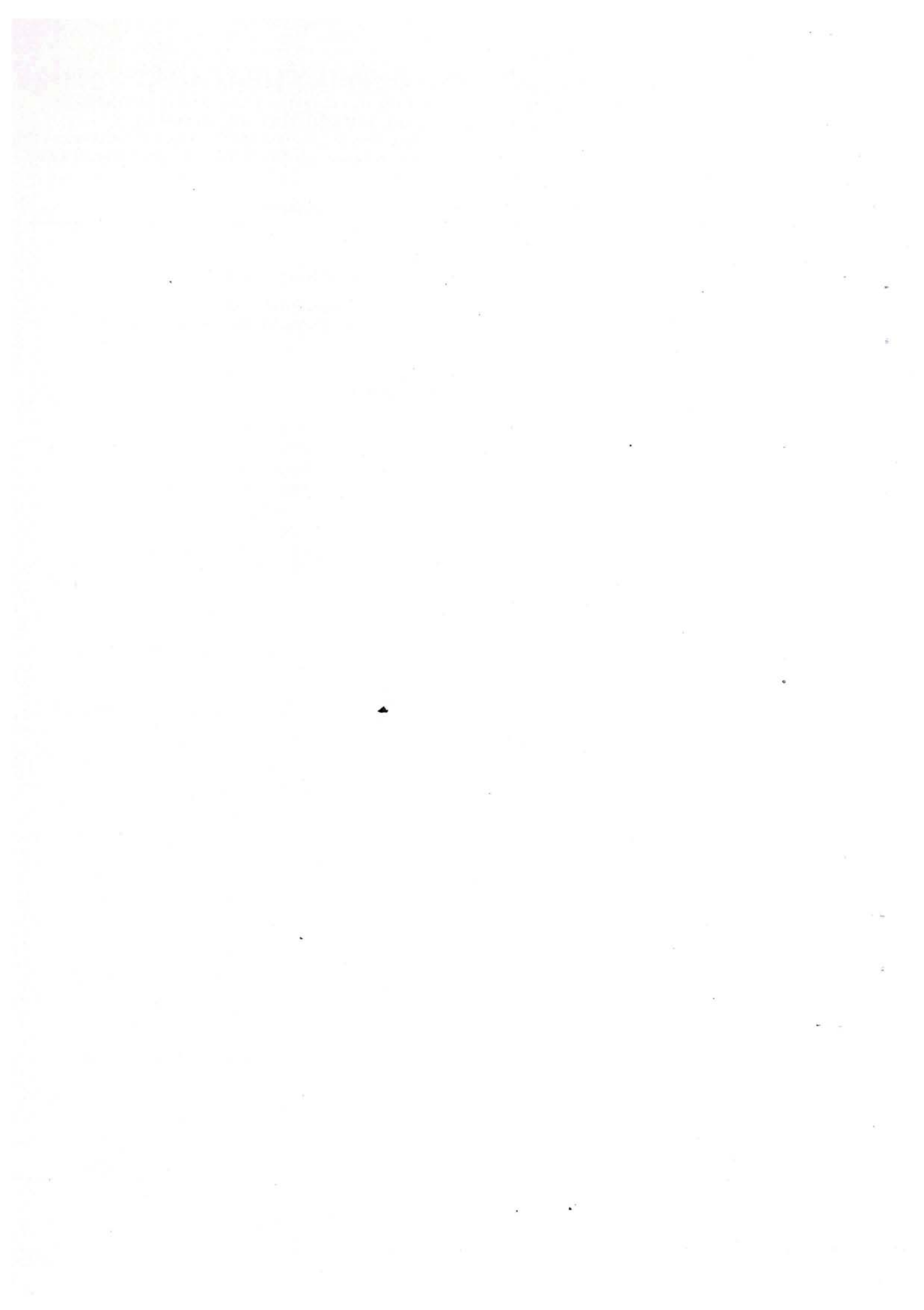



ANNEXURE VIII



Fly Ash Brick

डॉ. यश. मय्या / Y. S. Mayya  
परियोजना निदेशक / Project Director  
जी.सी.एन.ई.पी. डी.ए.ई. / GCNEP, DAE  
भारत सरकार, नो. ए. आर. सी. / Govt. of India B.A.R.C.  
मुंबई-४०० ०८५ / Mumbai - 400 085



ANNEXURE IX



Cement storage

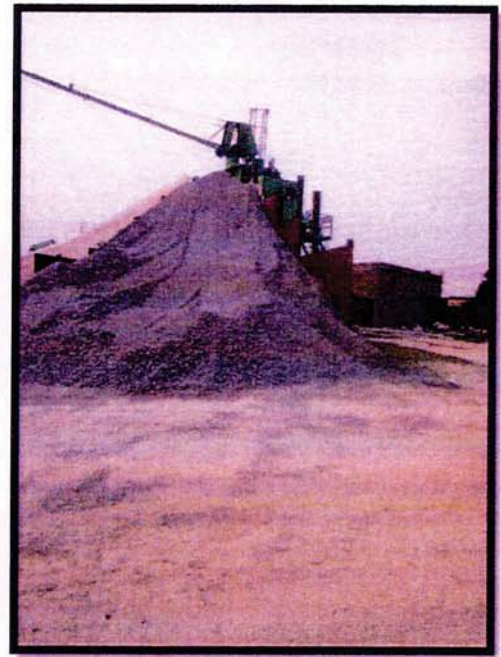

Batching Plant

डॉ. यश. मय्या / Y. S. Mayya  
परियोजना निदेशक / Project Director  
जी सी एन ई पी डी ए ई / GCNEP, DAE  
भारत सरकार, नो. ए. आर. सी / Govt. of India B.A.R.C.  
मुंबई-२०० ०८५ / Mumbai - 400 085.



## POWER REQUIREMENT

### Power Requirement :

- The total estimated power requirement for GCNEP Campus (Phase-I) is 1250 KVA.
- The total estimated power requirement for GCNEP residential (Phase-I) is 450 KVA.
- Source: UHBVN (Uttar Haryana Bijli Vitran Nigam).
- The energy consumption assumed is 10W/Sq. ft (including HVAC power requirement) for Campus area & 2 W/Sq.ft. (including AC & water heater power requirement) for Residential area.

### Backup Power supply details :

- 2 nos. DG set of 625 KVA capacities will be used as backup for Campus.
- 2 nos. DG set of 160 KVA capacities will be used as backup for Residential Township.

वै. एस. मय्या / Y. S. Mayya  
 परियोजना निदेशक / Project Director  
 जी सी एन ई पी, डी ए ई / GCNEP, DAE  
 भारत सरकार, वी. ए. आर. सी / Govt. of India B.A.R.C.  
 मुंबई-४०० ०८६ / M.

# ENERGY BALANCE ( CAMPUS )

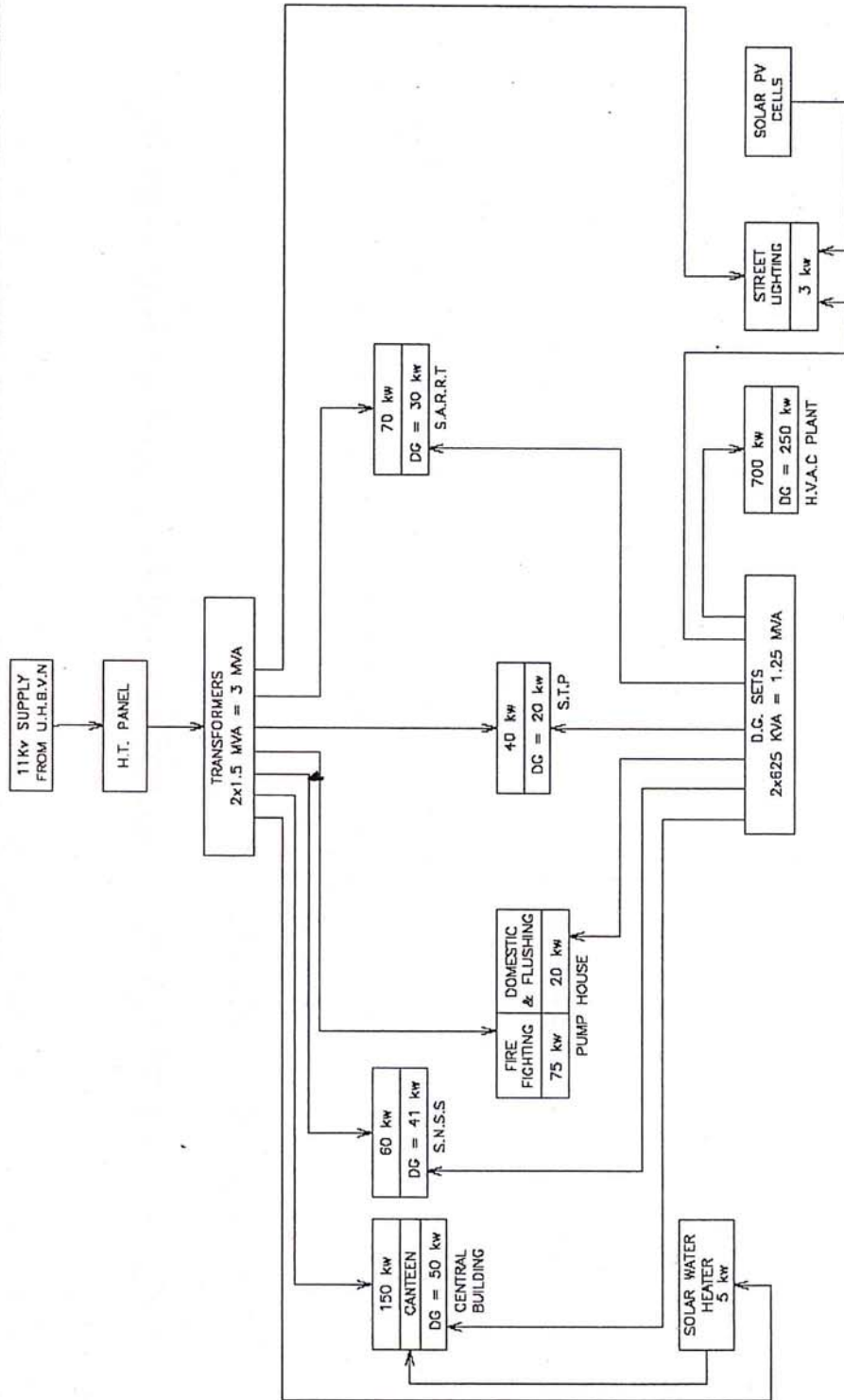

**PROJECT:** GLOBAL CENTER FOR NUCLEAR ENERGY PARTNERSHIP, BAHADURGARH, HARYANA  
**TITLE:** ENERGY (POWER) BALANCE PLAN  
**PRELIMINARY DRAWING**  
**DCSE**  
 Govt. of India  
 DIRECTORATE OF CONSTRUCTION SERVICES AND ESTATE MANAGEMENT  
 ELECTRICAL AND MECHANICAL DESIGN SECTION  
 10/04/2004 BHARU, MUMBAI/INDIA. MUMBAI-10004

DRG. NO. DCSE/E&M/GCNEP/CS/02/1546  
 SCALE DATE DRAWN DESIGNED CHECKED APPROVED  
 N.T.S 03-09-14 SVM S. JADHAV

डॉ. यश. मय्या / Y. S. Mayya  
 परियोजना निदेशक / Project Director  
 जी सी एन ई सी ए ई / GCNEP, DAE  
 भारत सरकार, वी. ए. आर. सी. / Govt. of India B.A.R.C.  
 मुंबई-400 085. / Mumbai - 400 085.

# ENERGY BALANCE (TOWNSHIP)

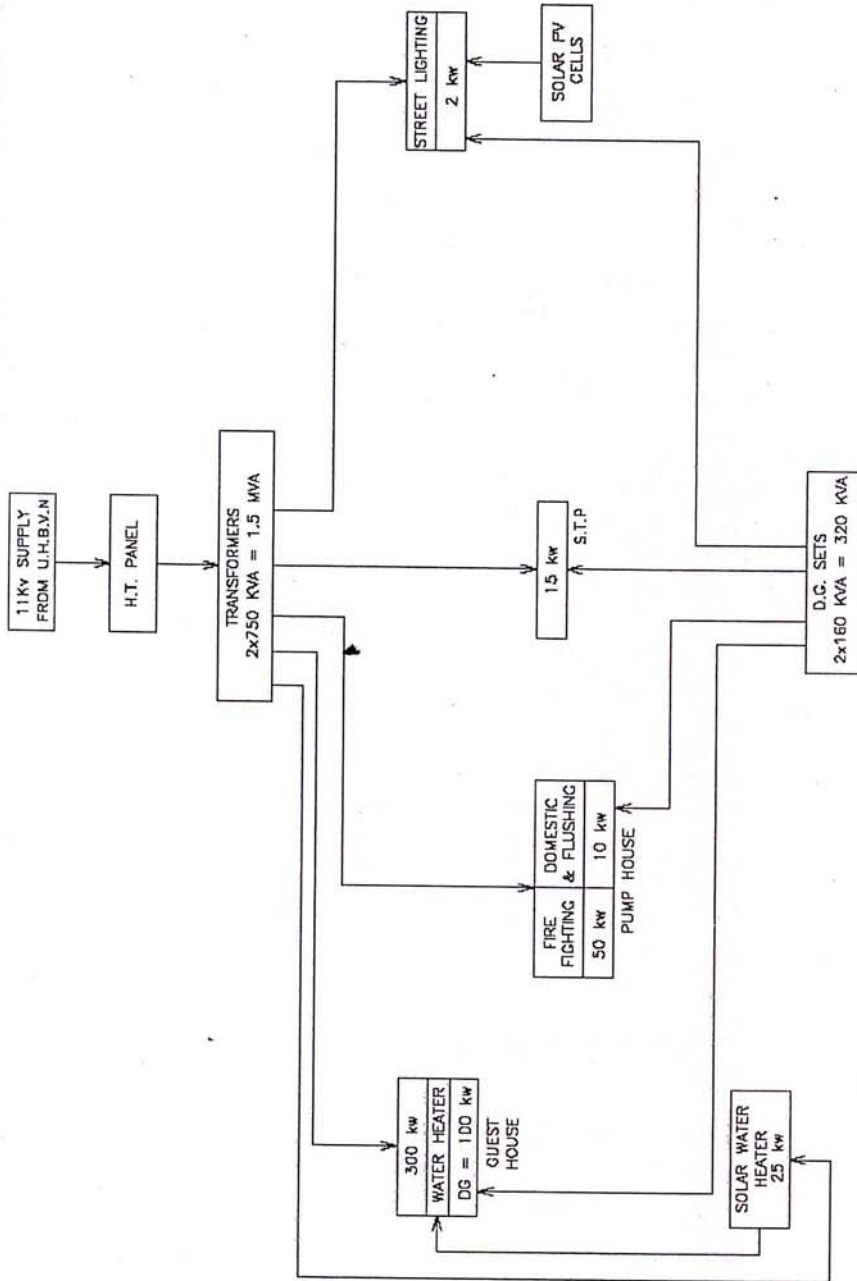

PROJECT: GLOBAL CENTER FOR NUCLEAR ENERGY PARTNERSHIP, BAHADURGARH, HARYANA  
 TITLE: ENERGY (POWER) BALANCE PLAN  
 REF. DRG. NO.: 47120260/04R/GCNEP/01 REV-1  
 DPG. NO.: DCSE/E&M/GCNEP/15/02/1547  
 SCALE: N.T.S. DATE: 03-09-14 DRAWN: S. JADHAV  
 CHECKED: APPROVED:

PRELIMINARY DRAWING  
 REV. R.O.  
 R.C.

GOVT. OF INDIA  
 DIRECTORATE OF CONSTRUCTION SERVICES AND ESTATE MANAGEMENT  
 ELECTRICAL AND MECHANICAL DESIGN SECTION  
 WORK: BAHADUR GARH, MURDHANAGAR, MUMBAI-10004

**DSEM**

W  
 00

दै. यश. मय्या / Y. S. Mayya  
 परियोजना निदेशक / Project Director  
 जी सी एन ई सी, डी ए ई / GCNEP, DAE

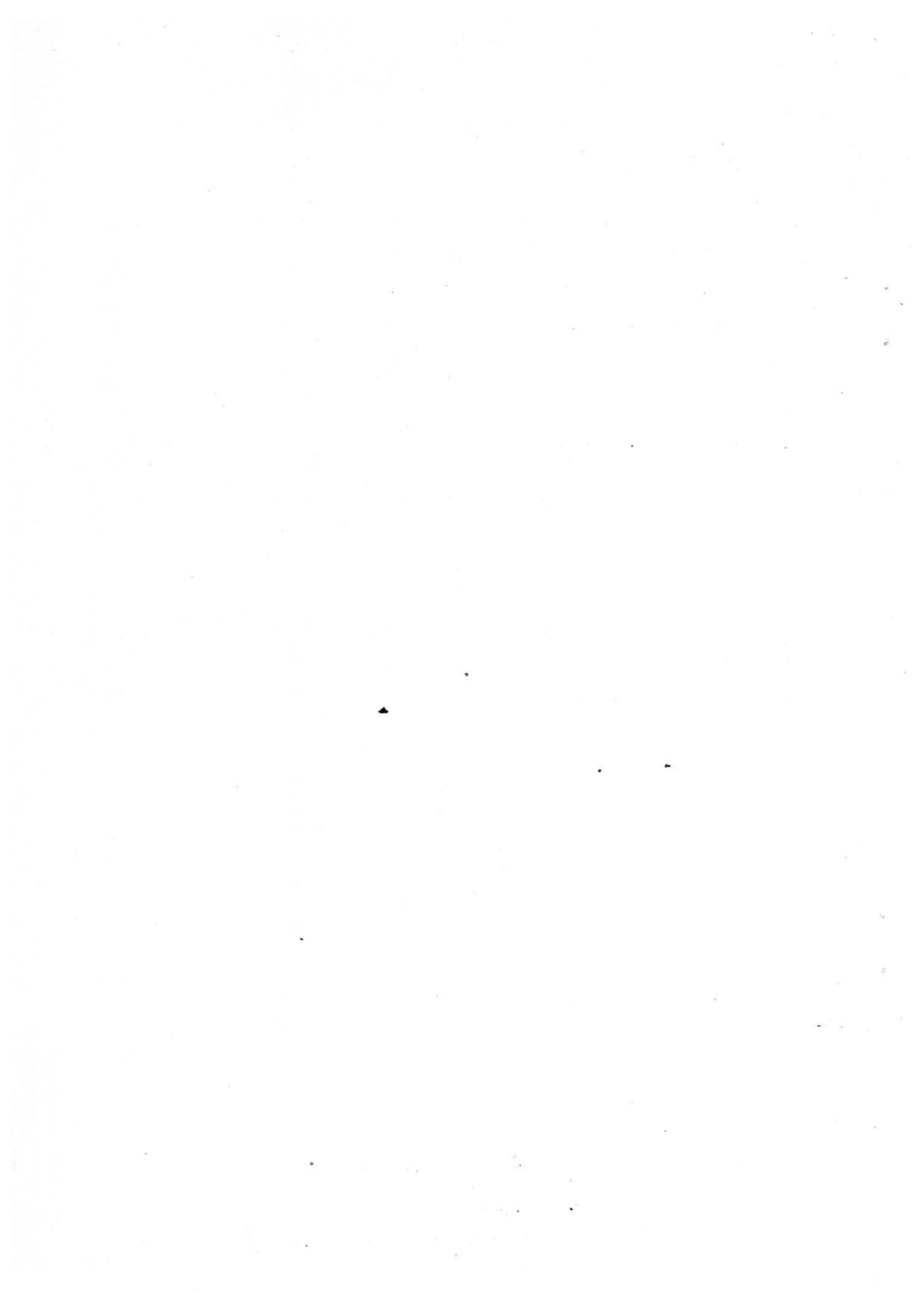



वन मण्डल अधिकारी (क्षेत्रीय), झज्जर

बाग जॉहआरा स्टेडियम, नजदीक DSP Residence, झज्जर

दुरभाष 01251-257258 e-mail:- dfojajjar@yahoo.co.in, dfojajjar@rediffmail.com

सेवा में:-

Ms. Y.S. Mayya, OS  
Project Director, GCNEP  
(Global Centre for Nuclear Energy Partnership),  
DAE, Govt. of India,  
RCnD, BARC, Mumbai-85.

क्रमांक:- 3293 दिनांक:- 27-12-2013

विषय:- Construction of Institutional Campus and Residential Township for Global Centre for Nuclear Energy Partnership (GCNEP) at Kheri-Jassor and Jassor-Kheri village, Bahadurgarh in the State of Haryana.

संदर्भ:- आपका पत्रांक GCNEP/81 दिनांक 26.12.2013

--00--

उपरोक्त विषय के सम्बन्ध में आप द्वारा प्रस्तुत किये गये खसरा न0 व किला न0 में किसी प्रकार की वन भूमि शामिल नहीं है। इसलिये आप द्वारा प्रस्तुत किये गये खसरा न0 व किला न0 में Institutional Campus and Residential Township for Global Centre for Nuclear Energy Partnership (GCNEP) का निर्माण करने पर इस कार्यालय को कोई आपत्ति नहीं है।

संलग्न - उपरोक्त खसरा सूची

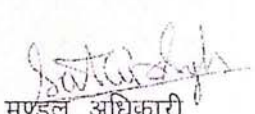
  
वन मण्डल अधिकारी,  
झज्जर।

डॉ. य.स. मय्या / Y. S. Mayya  
परियोजना निदेशक / Project Director  
जी सी एन ई पी. डी ए ई / GCNEP, DAE  
भारत सरकार, डॉ. ए. आर. सी / Govt. of India B.A.R.C.  
मुंबई-400 025 / Mumbai - 400 085.

**HARYANA GOVERNMENT  
DEVELOPMENT AND PANCHAYATS DEPARTMENT  
ORDER**

No.

Whereas the Gram Panchayat Khari Jasaur passed a resolution No. 1 dated 8.4.2010 for sale of its land measuring 123 Acre 2 Kanal 17 Marla falling in khasra Nos. 82/1(7-11), 82/2(8-0), 8(8-0), 7(8-0), 4(8-0), 9(8-0), 10(8-0), 11(8-0), 12(8-0), 13(8-0), 14(8-0), 15(8-0), 16(8-0), 17(8-0), 18(8-0), 19(8-0), 20(8-0), 21(8-0), 22(8-0), 23(8-0), 24(8-0), 25(8-0), 83/1(8-0), 2(8-0), 3(8-0), 5(8-15), 6(8-10), 7(8-12), 8(8-0), 9(8-0), 10(8-0), 11(7-12), 12(8-0), 13(8-0), 14(8-14), 15(8-3), 16(4-16), 17(8-12), 18(8-0), 19(8-0), 20(7-12), 21(7-12), 22(8-0), 23(8-0), 24(7-11), 25(3-18), 84/5/2(2-5), 8(8-0), 15(8-0), 92/5(7-2), 6(8-0), 15(8-0), 16(8-0), 17(8-0), 18(8-0), 93/3(7-11), 4(7-11), 5/1(1-3), 1(7-3), 2(7-11), 5/2(3-4), 8/1(2-12), 11(7-12), 12(8-0), 13(8-0), 14(8-0), 15/1(2-0), 15/2(2-0), 16/1(1-14), 18/2(2-14), 17(8-0), 18(8-0), 6/2(1-16), 7(8-0), 8(8-0), 9(8-0), 10(7-12), 19(8-0), 20(7-12), 23(8-0), 24(8-0), 25/1(3-4), 25/2(1-4), 94/1(8-0), 2(8-0), 3(8-0), 4(8-0), 5(8-0), 6(8-0), 7(8-0), 8(8-0), 9(8-0), 10(8-0), 11(8-0), 12(8-0), 13(8-0), 14(8-0), 15(8-0), 17(8-0), 18(8-0), 19(8-0), 20(8-0), 62/16(7-4), 25(8-0), 63/21(9-18), 22(4-18), 115/1(8-0), 2(8-0), 3(8-0), 8(8-0), 9(8-0), 10(7-8), 11(7-2), 12(8-0), 13(8-0), 17/3(2-2), 18(8-0), 19(8-0), 20(8-4), 21/2(4-12), 22(8-0), 23/1(8-13), 116/5/2(8-18), 125/1/2(2-0), 2(7-12), 3/1(3-11), 9(8-3), 10/1(8-4), 94/21(8-0), 22(8-0), 23(8-0), 24(8-0), 81/1(8-0), 2(8-0), 3(8-0), 8(8-0), 9(8-0), 10(8-0), 11(8-0), 12(8-0), & 13(8-0) and the Gram Panchayat Jasaur Khari, Block Bahadurgarh, District Jhajjar passed a resolution No. 1 dated 8.3.2010 for sale of its land measuring 83 Acre 4 Kanal 16 Marla falling in Khasra No. 82/12(8-0), 82/13(8-0), 82/8(8-0), 82/9(8-0), 65/20(8-0), 63/6(8-0), 83/7(8-0), 83/5(8-0), 64/8(8-0), 64/9(8-0), 65/11(8-0), 65/12(8-0), 82/1(8-0), 82/20(8-0), 82/21(8-0), 82/19(8-0), 82/22(8-0), 82/10(8-0), 82/11(8-0), 30/22/2(4-8), 30/23(8-0), 30/24(8-0), 30/25/1(8-14), 50/19(8-0), 50/20(8-0), 64/1/2(4-0), 64/2(8-0), 64/3(8-0), 64/6(8-0), 64/7(8-0), 100/3(8-0), 100/4(8-0), 100/7(1-18), 100/8(1-13), 65/1(8-0), 51/2(8-0), 51/3(8-0), 51/4(10-8), 65/2(8-0), 64/4(8-0), 64/5(8-0), 51/16(8-0), 51/17(8-8), 51/24(8-12), 51/25(8-0), 50/21(8-0), 50/22(8-0), 60/23(8-0), 50/8(8-0), 50/11(8-0), 50/12(8-0), 50/13(8-0), 64/16(8-0), 64/17(8-0), 64/18(8-0), 64/19/1(4-0), 64/22/2(3-18), 64/23(8-0), 64/24(8-0), 64/25(8-0), 65/21(8-0), 51/15(11-2), 50/24(8-0), 60/25(7-12), 64/12(8-0), 64/13(8-0), 64/14(8-0), 64/15(8-0), 55/9(8-0), 65/10(8-0), 82/18(8-0), 82/23(8-0), 100/1(8-0), 100/2(8-0), 100/8(1-2), 100/10(8-18), 100/5(8-0), 100/6(1-7), 82/24(8-0), 82/25(8-0), 82/14(8-0), 82/7(8-0), 82/15(8-0), 50/16(8-0), 50/18(8-0), 51/7(8-14), 51/8(8-0), 51/9(8-0), 51/12/1(2-0), 51/13/1(7-2) & 51/14/1(3-2) (total area of both the Gram Panchayats is 206 Acre 7 Kanal 13 Marla) to the Department of Atomic Energy, Government of India for the purpose of establishing Centre of Excellence for Global Deployment of Nuclear Energy at Market rate.

श्री. यश्या / Y. S. Mayya

प्रियोजना निदेशक / Project Director

जी सी एन ई पी, डी ए ई / GCNEP, DAE

भारत सरकार की पं. आर. सी. / Govt. of India B.A.R.C.

मुंबई-४०० ०८५ / Mumbai - 400 085.

From,

Fire Station Officer,  
Bahadurgarh(Jhajjar)

To,

Director,  
Haryana Fire Service,  
Bays No.11-14, Sector-4,  
Panchkula (Haryana)

No. 168/FSB

Dated 07-05-2015

Subject:- Approval of part fire fighting scheme Educational Building of School Of Nuclear Security Studies (SNSS) of Global Center for Nuclear Energy Partnership (GCNEP) in the Village- Kheri Jassaur and Jassaur Khari Tehsil- Bahadurgarh Distt. Jhajjar (HR).

\*\*\*\*\*

Global Center for Nuclear Energy Partnership (GCNEP), Village - Kheri Jassaur and Jassaur Khari Tehsil- Bahadurgarh Distt. Jhajjar (HR) has applied the subject cited above case for approval of fire fighting scheme of Educational Building of School of Nuclear Security Studies (SNSS) from fire safety point of view.

I have inspected the site and examined the fire fighting scheme in the above said building (Shown in plan and Questionnaire) and found that the building having Maximum Height of Building is 16.15 mtrs, Occupied Height is 13.15 mtrs and Total Plot Area is 522515.73 Sq. mtrs and Total plot Area of Education building is 7552.74 sq.mts and covered area of building is 2175.26 sqm. Proposed Fire Fighting scheme of the building as per National Building Code of India 1983 Part-IV Revised 2005 and type of occupancy group-B. Sub B-1(ii). Detail of Proposed fire fighting scheme as under:-

Sr. No	Installation norms as per NBC	Required	Proposed Installation of fire fighting scheme
1	Fire extinguishers	Yes	Yes
2	Hose Reel	Yes	Yes
3	Under ground water storage Tank	NA	Yes cap. 50 KL
4	Terrace water Tank	Yes	Yes cap.10 KL
5	Down Comer	Yes	Yes provided
6	Yard Hydrant	Yes	Yes
7	Pump	Yes	Terrace Pump 450 LPM

The Proposed part fire fighting scheme in the building were checked and found as per National Building Code of India 1983 Part-IV revised 2005. I recommending above said case for approval of part Fire Fighting scheme of Educational building so that permission of part Fire Fighting Scheme can be issued to the applicant.

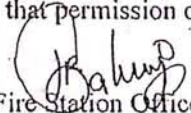
  
Fire Station Officer,  
Bahadurgarh (Jhajjar)

वै. चरा. मय्या / Y. S. Mayya

परियोजना निदेशक / Project Director

जी सी एन ई पी, डी ए ई / GCNEP, DAE

भारत सरकार, वी. ए. आर. सी / Govt. of India B.A.R.C.

मुंबई-४०० ०८५ / Mumbai - 400 085.

From,

Fire Station Officer,  
Bahadurgarh(Jhajjar)

To,

Director,  
Haryana Fire Service,  
Bays No.11-14, Sector-4,  
Panchkula (Haryana)

No. 169/FSB

Dated 07.05.2015

Subject:- Approval of part fire fighting scheme Residential Building - Guest House Block A of Global Center for Nuclear Energy Partnership (GCNEP) in the Village-Kheri Jassaur and Jassaur Khari Tehsil- Bahadurgarh Distt. Jhajjar (HR).  
\*\*\*\*\*

Global Center for Nuclear Energy Partnership (GCNEP), Village - Kheri Jassaur and Jassaur Khari Tehsil- Bahadurgarh Distt. Jhajjar (HR) has applied the subject cited above case for approval of part fire fighting scheme of Residential Building for Guest House Block A from fire safety point of view.

I have inspected the site and examined the fire fighting scheme in the above said building (Shown in plan and Questionnaire) and found that the building having Maximum Height of Building is 10.7 mtrs, Occupied Height is 7.8 mtrs and Total Plot Area is 424021.48 Sq. mtrs and Total plot Area of Guest House Block A building is 7748.35 sq.mts and covered area of building is 1261.65 sqm. Proposed Fire Fighting scheme of the building as per National Building Code of India 1983 Part-IV Revised 2005 and type of occupancy group-A. Detail of Proposed fire fighting scheme as under:-

Sr. No	Installation norms as per NBC	Required	Proposed Installation of fire fighting scheme
1	Fire extinguishers	Yes	Yes
2	Hose Reel	Yes	Yes
3.	Terrace water Tank	Yes	Yes cap.10 KL
4.	Down Comer	Yes	Yes provided
5.	Internal Hydrant	Yes	Yes
6.	Pump	Yes	Terrace Pump 450 LPM

The Proposed part fire fighting scheme in the building were checked and found as per National Building Code of India 1983 Part-IV revised 2005. I recommending above said case for approval of part Fire Fighting scheme of Guest House Block A building so that permission of part Fire Fighting Scheme can be issued to the applicant.

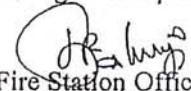
  
Fire Station Officer,  
Bahadurgarh (Jhajjar)

✓

Ref: GCNEP / Elec/01

Date: 26<sup>th</sup> December 2013

To  
Project Director, GCNEP  
Reactor Control Division,  
Bhabha Atomic Research Centre  
Mumbai.

Sub: *Construction of Institutional Campus and Residential Township for Global Centre for Nuclear Energy Partnership (GCNEP) at KheriJasaur and JasaurKheri village in the State of Haryana*

- Electric Supply for GCNEP Campus & Township

Ref: 1. Your letter dated 26.12.13 and Check list received from State Environment Impact Assessment Authority (SEIAA).

Dear Sir,

This is to assure you that the necessary Electricity supply shall be provided for, both the sites at KheriJasaur and Jasaur Kheri villages, for setting up GCNEP project. *as per Affair Instruction*



SDO HBVN,  
Bahadurghar, Haryana.  
SDO S/U S/DIVN,  
Bahadurghar

वै. यस. मय्या / V. S. Mayya  
परियोजना निदेशक / Project Director  
जी सी एन ई पी, डी ए ई / GCNEP, DAE  
भारत सरकार, बी. ए. आर. सी / Govt. of India B.A.R.C.  
मुंबई-४०० ०८५ / Mumbai - 400 085.

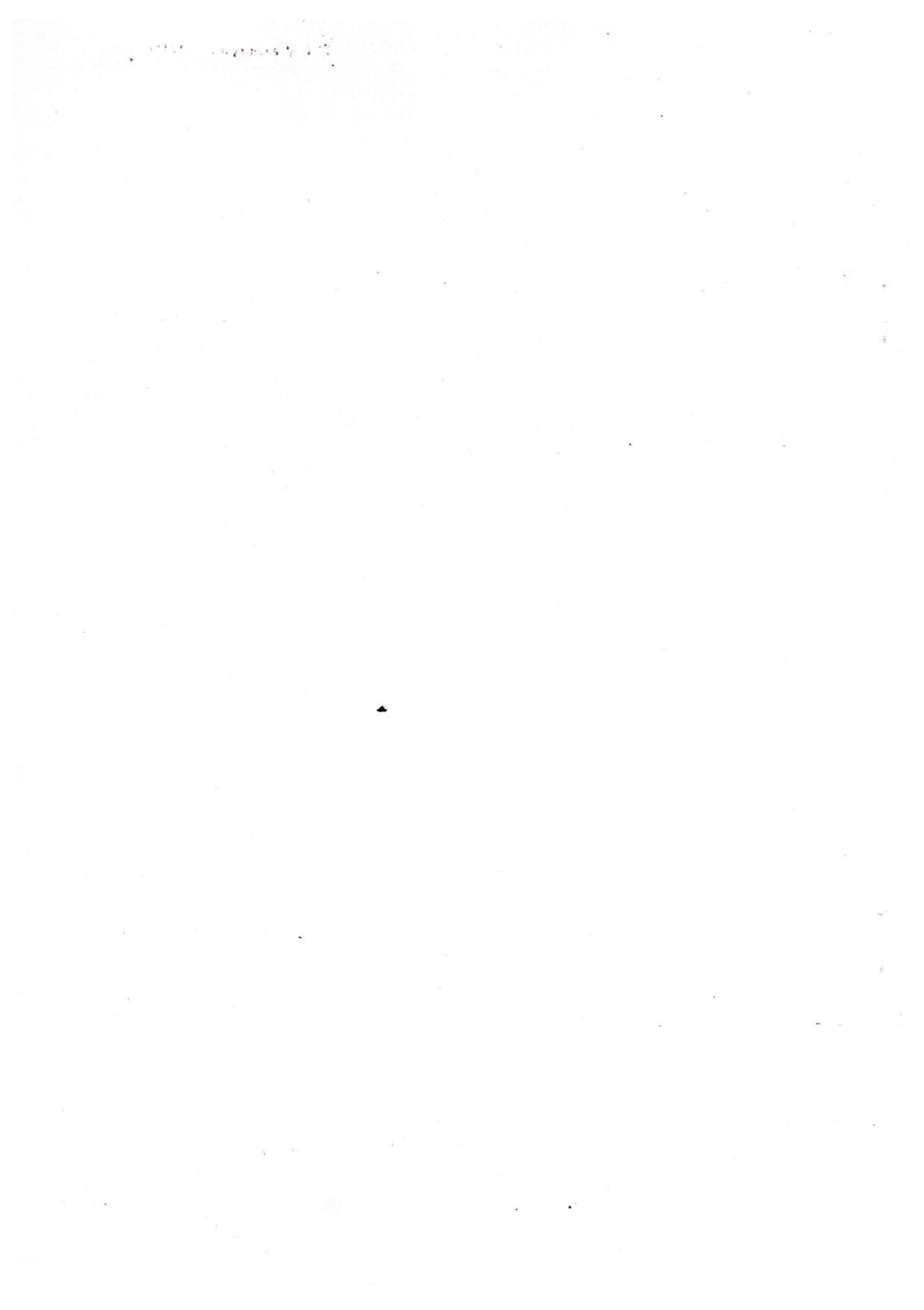



Government of India  
भारत सरकार

Phone: +912225595204

परमाणु ऊर्जा विभाग  
Department of Atomic Energy  
वैश्विक नाभिकीय ऊर्जा साझेदारी केन्द्र

GLOBAL CENTRE FOR NUCLEAR ENERGY PARTNERSHIP



Y. S. Mayya, OS  
Project Director, GCNEP

Ref: GCNEP / 83

Date: 26<sup>th</sup> December 2013

To  
The Chairman, SEIAA  
Parytan Bhawan  
1<sup>st</sup> Floor, Sector-2, Panchkula  
Tel: 0712 2565232

Sub: *Construction of Institutional Campus and Residential Township for Global Centre for Nuclear Energy Partnership (GCNEP) at Kheri Jasaur and Jasaur Kheri village in the State of Haryana.*

- Submission of Form-1, Form-1A, Environmental Management Plan and Conceptual Plan for Environmental Clearance

Ref: 1. Department's proposal submitted on 30 October 2013.  
2. Check list received from State Environment Impact Assessment Authority (SEIAA) dated 06.11.2013 received on 09.12.13.

Dear Sir,

Department of Atomic Energy, Government of India decided to set up institutional campus and residential township for Global Centre for Nuclear Energy Partnership (GCNEP) project at Kheri Jasaur and Jasaur Kheri village near Bahadurgarh, in the State of Haryana.

The details of the project were submitted to your office with reference to point no.1.

Further as per the prerequisite in check list above referred at point no.2, We Undertake the following:-

- That no construction has been started at the site along with latest attested photograph.
- That we will not encroach the revenue rasta passing through the project area shown in the zoning plan and layout plan.
- That we will keep the ROW required for HT wire passing through the project area as per Government instruction.
- That we will not use ground water for construction and will use treated water confirmation the ISI standards for building construction.
- That we will use ultra low sulphur diesel.
- That provision for Helipad shall be made in case of the building having height more than 6 meter. Provision of atleast one Hydraulic ladder for high rise building shall also be made.
- The infrastructure will not obstruct or divert the natural flow of water covered or open nallah, drainage of rain water as per natural flow of water.

Thanking you

Yours faithfully

Project Director, GCNEP  
Reactor Control Division, Bhabha Atomic Research Centre  
Tel: 022 2559 5204  
E-mail: ysmayya@barc.gov.in

Y. S. MAYYA  
Project Director, GCNEP  
DAE, Govt. of India  
RCnD, BARC, Mumbai-85

वाई.एस. मय्या / Y.S. MAYYA  
परमाणु ऊर्जा विभाग / Project Director  
वैश्विक नाभिकीय ऊर्जा साझेदारी केन्द्र (जी.सी.एन.ई.पी.)  
Global Centre for Nuclear Energy Partnership (GCNEP)  
भारत सरकार / Government of India  
रेक्टर नियंत्रण प्रभाग / Reactor Control Division  
Bhabha Atomic Research Centre, Mumbai-400085

Global Centre for Nuclear Energy Partnership  
Reactor Control Division  
Trombay, Mumbai - 400085

Y. S. Mayya  
Project Director  
GCNEP, DAE  
Govt. of India, B.A.R.C.  
Mumbai-400085





ANNEXURE XIII XV

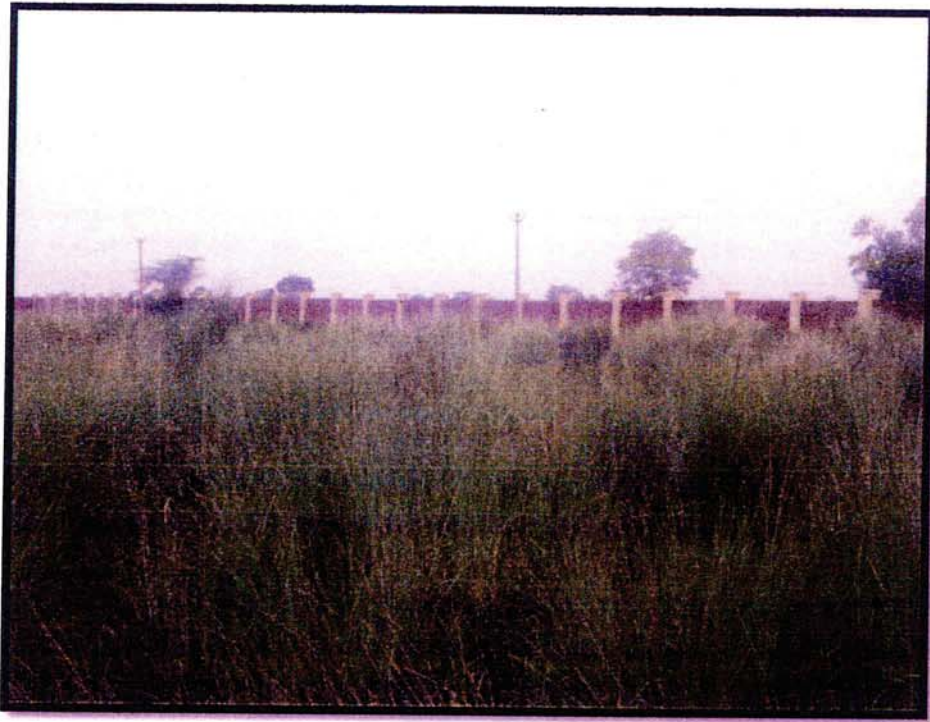

**Site Barricade with High wall**

*(Handwritten signature)*

डॉ. यश. भय्या / Y. S. Mayya  
परियोजना निदेशक / Project Director  
आर. सी. एन. ई. पी. डी. ए. ई. / GCNEP, DAE  
भारत सरकार, न्यू ए. आर. सी / Govt. of India B.A.R.C  
मुंबई - ४०० ०८५ / Mumbai - 400 085.



## ANNEXURE XIVI

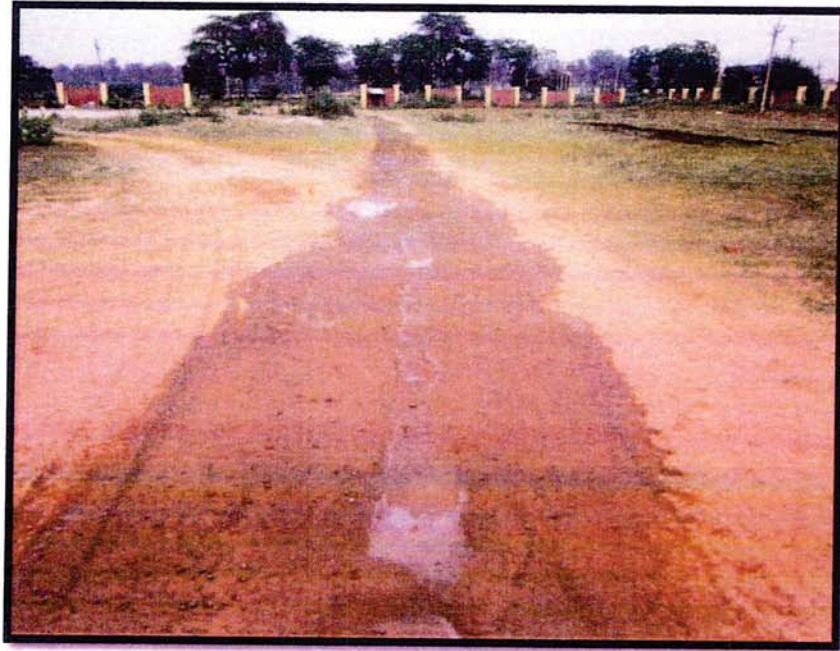

**Water Sprinkling at Site.**

डॉ. यस. मय्या / Y. S. Mayya  
परियोजना निदेशक / Project Director  
जी सी एन ई पी, डी ए ई / GCNEP, DAE  
भारत सरकार, वी. ए. आर. सी / Govt. of India B.A.R.C.  
मुंबई-४०० ०८५ / Mumbai - 400 085.



ANNEXURE XVII

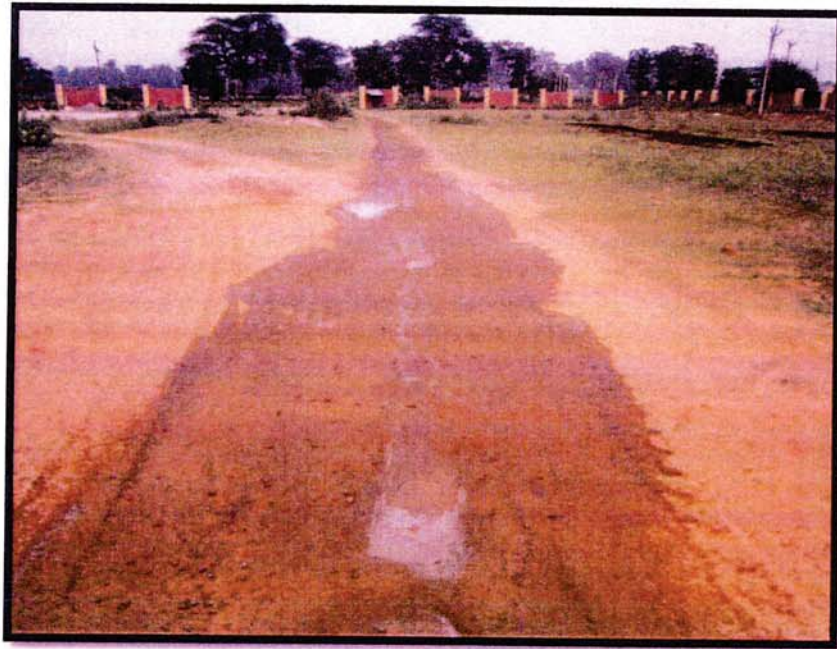

✓

डॉ. वसु. मय्या / V. S. Mayya  
परियोजना निदेशक / Project Director  
सी सी एन ई पी, डी ए ई / GCNEP, DAE  
भारत सरकार, पो. १, अरं. सी / Govt of India B.A.R.C.  
मुंबई - ४०० ०८५ / Mumbai - 400 085.



# MASTER PLAN - INSTITUTIONAL CAMPUS

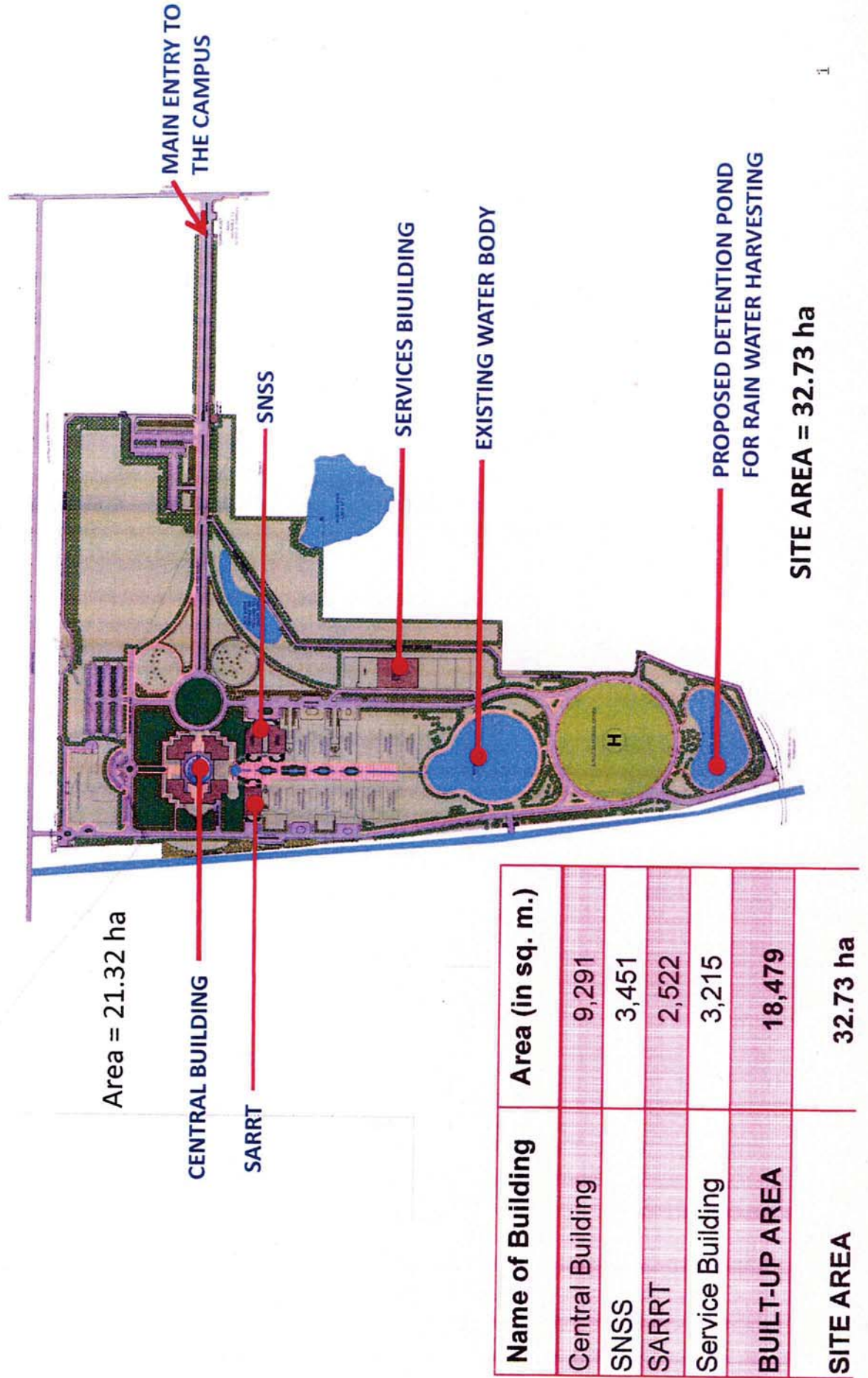

प्र. मय्या / Y. S. Mayya  
 प्रियोजना निदेशक / Project Director  
 ग. न. ए. डी. ए. सी. / GCNER, DAE  
 भारत सरकार / Govt. of India B.A.R.C.  
 मुंबई - 400 085





# MASTER PLAN - RESIDENTIAL TOWNSHIP

Name of Building	Area (in sq. m.)
GUEST HOUSE - BLOCK A	2,475.79
GUEST HOUSE - BLOCK B	3,858.03
Service Building	1619.18
<b>TOTAL BUILT-UP AREA</b>	<b>7953.00</b>
<b>SITE AREA</b>	<b>13.66 ha</b>

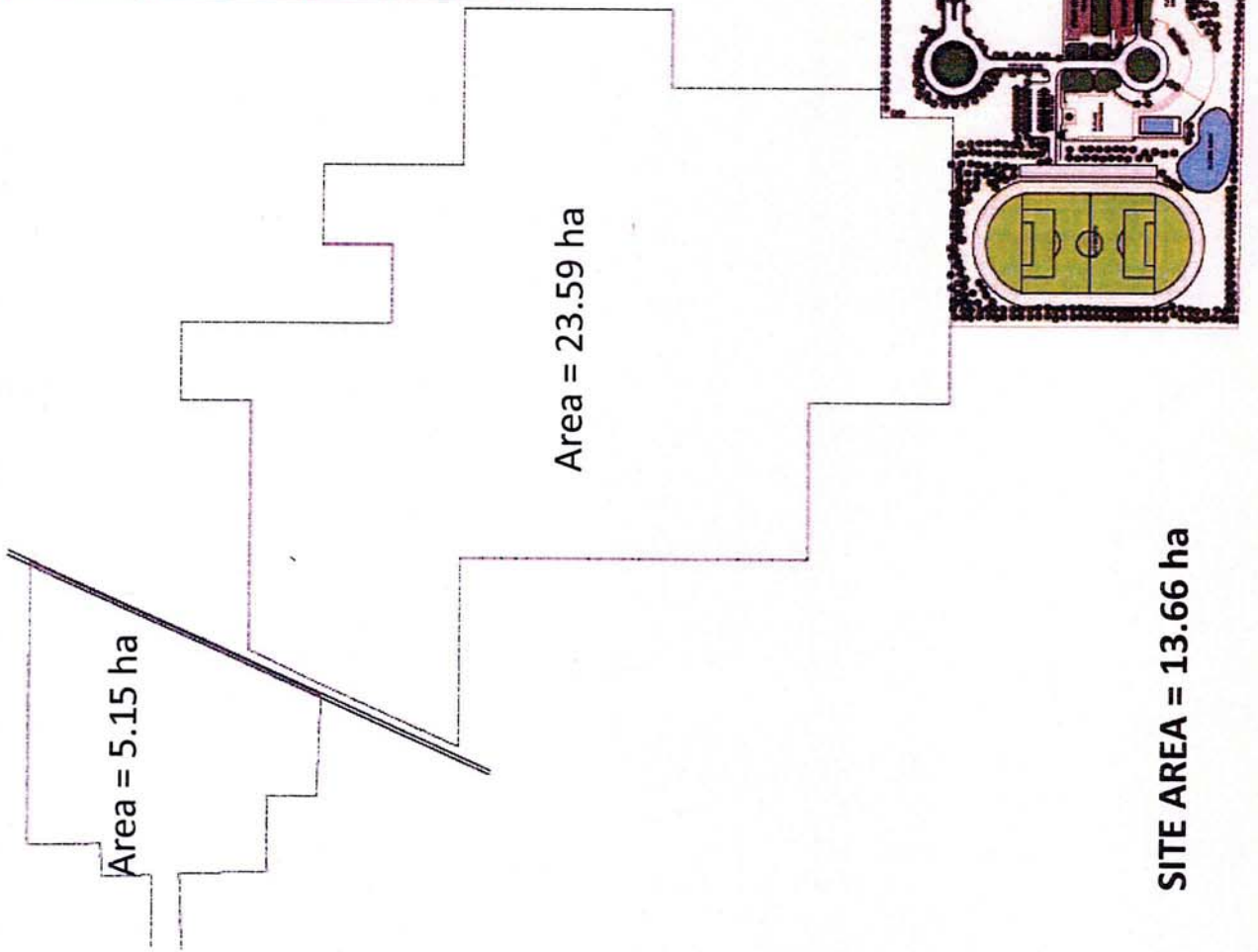

डॉ. यश. मय्या / Y. S. Mayya

परियोजना निदेशक / Project Director

ली सी एन ई सी डी ए ई / GCNEP, DAE

भारत सरकार के अधीन / Govt of India B.A.R.C

मुंबई-४०० ०८५ / Mumbai-400 085.

५७



**PARKING & CIRCULATION MASTER PLAN - CAMPUS**

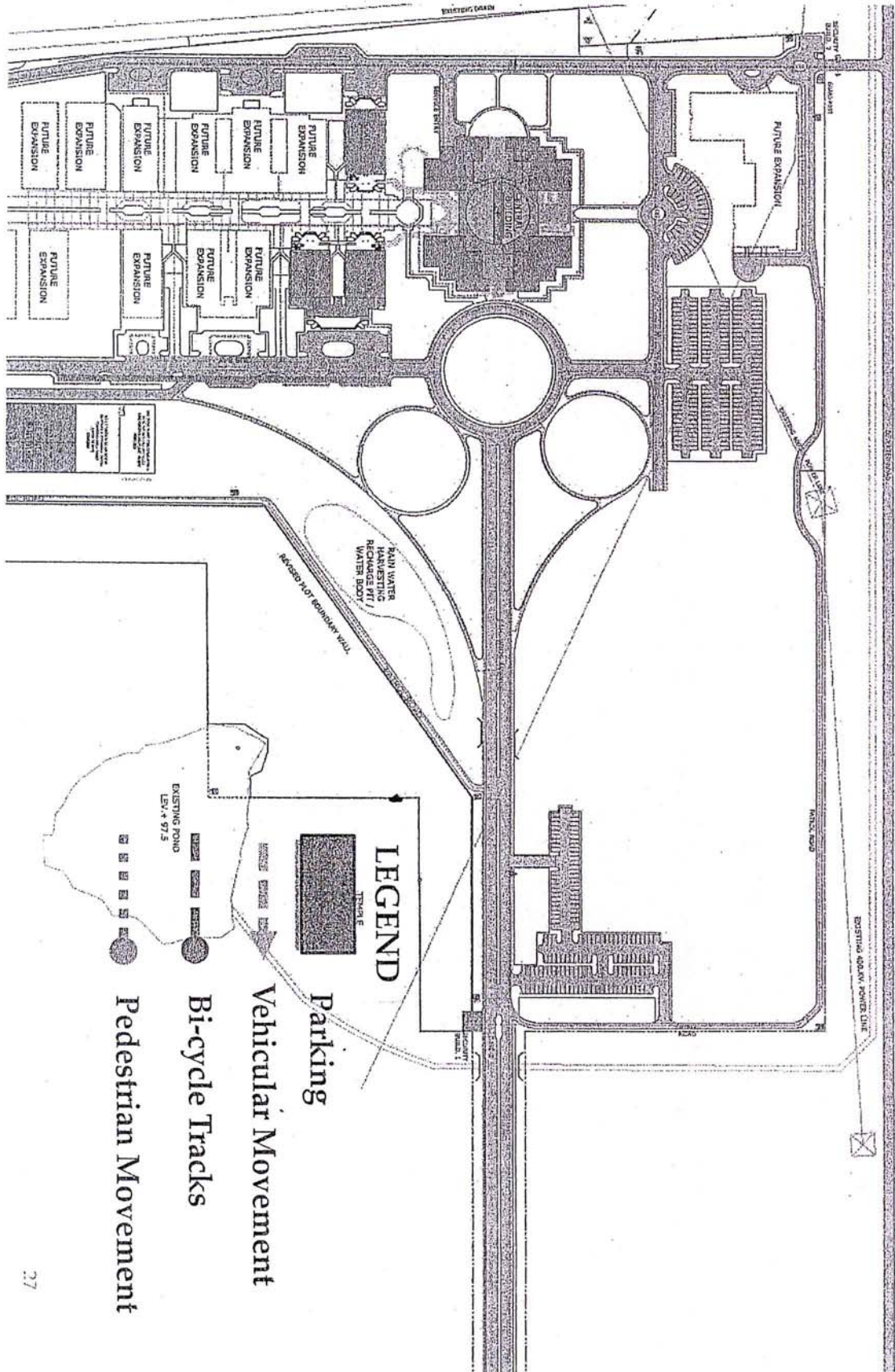

 ॐ. यश. मय्या / Y. S. Mayya  
 परियोजना निदेशक / Project Director  
 जी सी एन ई पी डी ए ई / GCNEP, DAE  
 भारत सरकार, पी. ए. आर. सी / Govt. of India B.A.R.C  
 मुंबई - ४०० ०८५ / Mumbai - 400 085. ५

1. 2. 3. 4. 5. 6. 7. 8. 9. 10.

# PARKING & CIRCULATION MASTER PLAN - TOWNSHIP

## LEGEND



Parking



Vehicular Movement



Bicycle Tracks



Pedestrian Movement

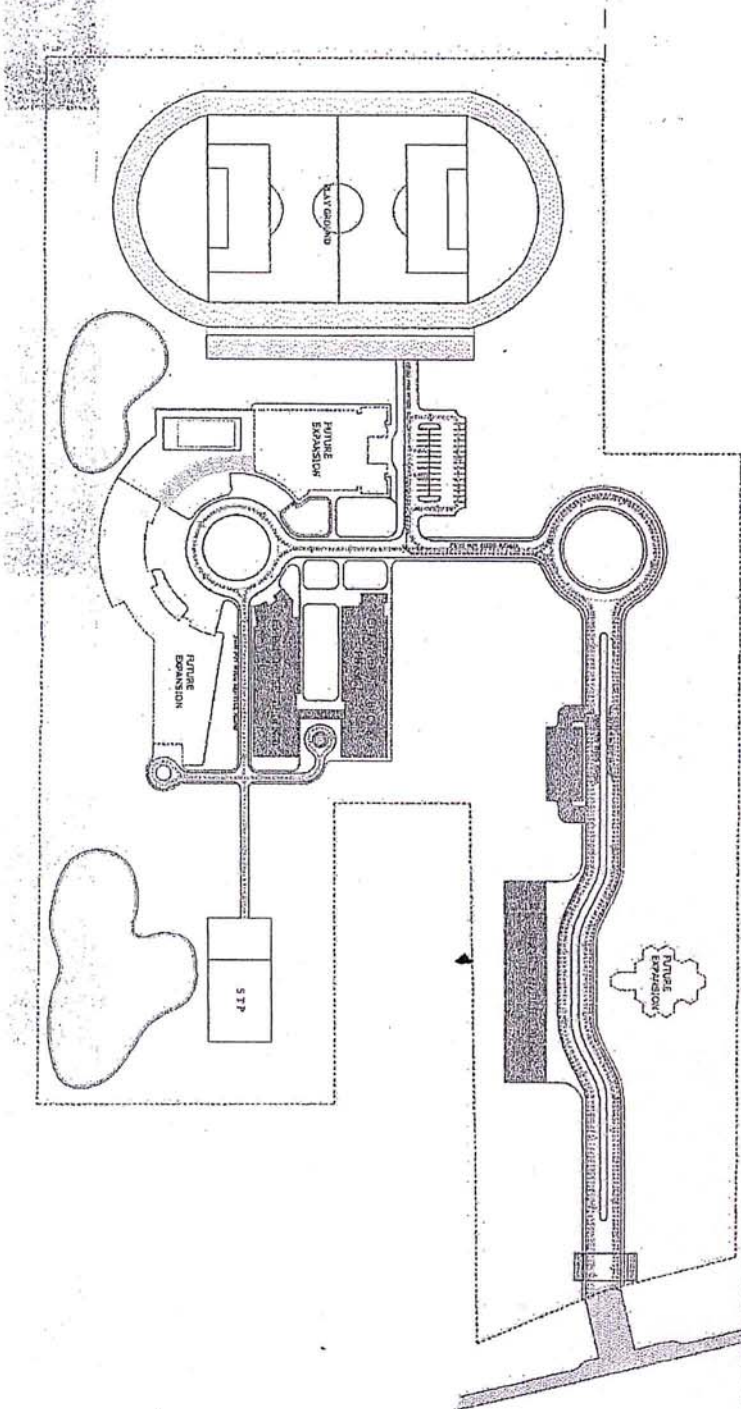

वै. यसा. मय्या / Y. S. Mayya

परियोजना निदेशक / Project Director

जी सी एन ई पी, डी ए ई / GCNEP, DAE

भारत सरकार, पी. ए. आर. सी / Govt. of India B.A.R.C.

मुंबई-४०० ०८५ / Mumbai - 400 085.

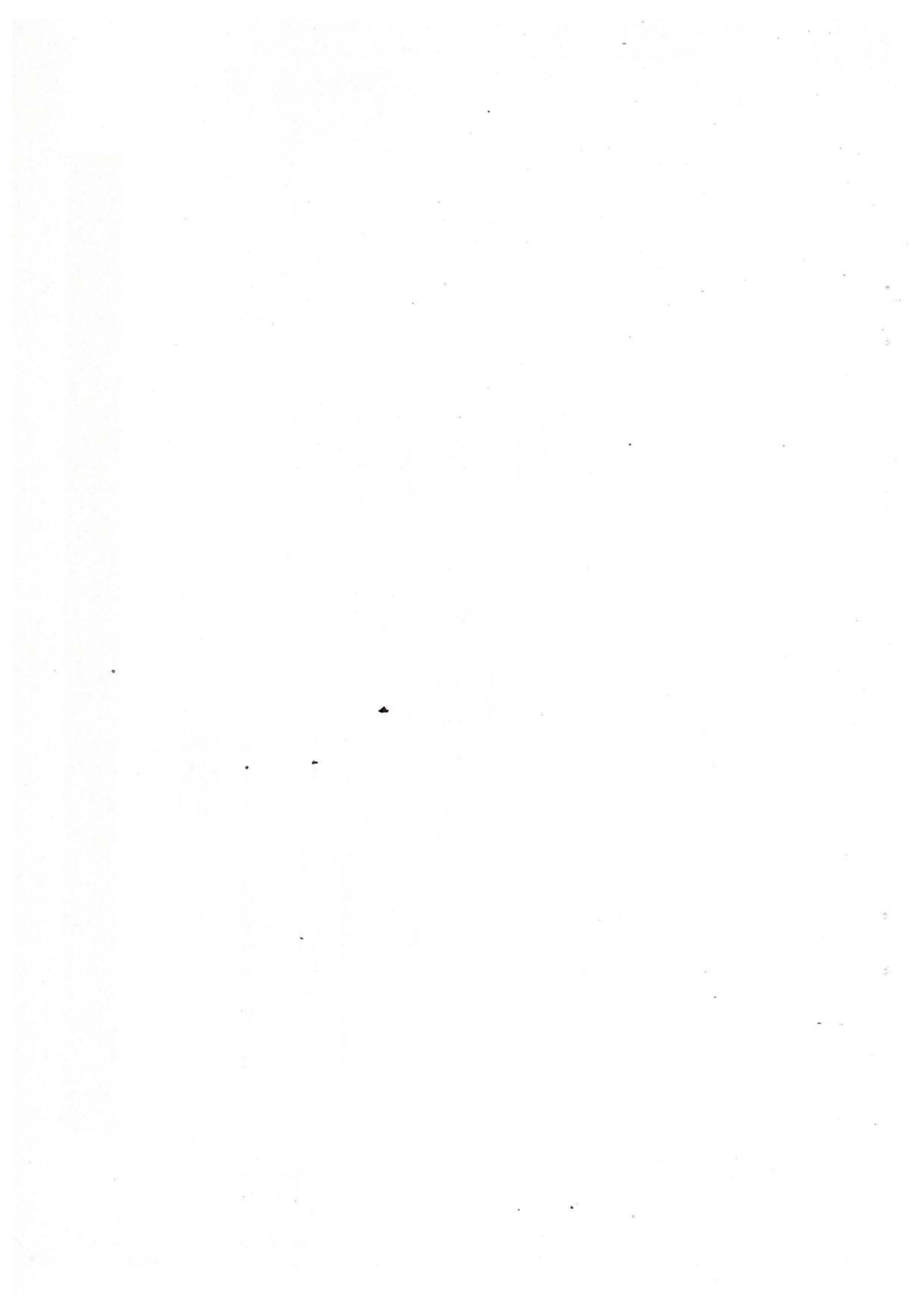

बाल व्रिसता सिमाप्त किरने क्रिा सिाकल्प



नई दिल्ली में नवंबर 2014 में बाल व्रिसता सिमाप्त किरने क्रिा सिाकल्प का कार्यक्रम हुआ।

पूर्व केंद्रीय मंत्री का करीबी बताकर 10 लाख हगे

अमर उजाला (नई दिल्ली) पूर्व केंद्रीय मंत्री का करीबी बताकर 10 लाख हगे... मंत्री के करीबी के नाम पर 2 लाख रेंटे... पूर्व केंद्रीय मंत्री का करीबी बताकर 10 लाख हगे...

मनी लॉन्ड्रिंग मामले में चार्जशीट दाखिल

नई दिल्ली 11 अक्टूबर को प्रवर्तन निदेशक ने मनी लॉन्ड्रिंग मामले में चार्जशीट दाखिल की... मनी लॉन्ड्रिंग मामले में चार्जशीट दाखिल...

जेल अधिकारियों के खिलाफ बयान दर्ज

पौराणिक (नई दिल्ली) जेल अधिकारियों के खिलाफ बयान दर्ज... जेल अधिकारियों के खिलाफ बयान दर्ज...

धौला कुआं गैंग रेप दौषी की सजा घटाई

नई दिल्ली (अमर उजाला) धौला कुआं गैंग रेप दौषी की सजा घटाई... धौला कुआं गैंग रेप दौषी की सजा घटाई...

जीजा ने किया दुष्कर्म

नई दिल्ली (अमर उजाला) जीजा ने किया दुष्कर्म... जीजा ने किया दुष्कर्म...

न्यूज डायरी

अदालत को विाखिया विावित डियरव्यू... न्यूज डायरी... अदालत को विाखिया विावित डियरव्यू...

भारत सरकार परमाणु उर्जा विभाग

भारत सरकार परमाणु उर्जा विभाग वैश्विक नाभिकीय उर्जा साझेदारी केन्द्र... Advt No.: GCNEP/Advt/14/11-1

सड़क पार कर रही महिला को ट्रैक्टर ने कुचला

सड़क पार कर रही महिला को ट्रैक्टर ने कुचला... परिचयाल विद्युत वितरण निगम लि.

धनंजय खिमले को सुनवाई मिली

धनंजय खिमले को सुनवाई मिली... परिचयाल विद्युत वितरण निगम लि.

कार्यालय नगर पालिका परिषद, हनुगुल जम्पर - हनुगुल

कार्यालय नगर पालिका परिषद, हनुगुल जम्पर - हनुगुल... अधिकाधिक नया पत्रिका

mydealshop.in Deal Code : A011501 नया दिन नया ऑफर... 39% OFF Exclusive Price... G'FIVE Spark A1

हरियाणा विद्युत परामर्श निगम लिमिटेड... कार्यालय जिला पंचायत राज अधिकारी, गौतम बुद्धनगर

CHHATTISGARH STATE POWER DISTRIBUTION COMPANY LTD. कार्यालय जिला पंचायत राज अधिकारी, गौतम बुद्धनगर







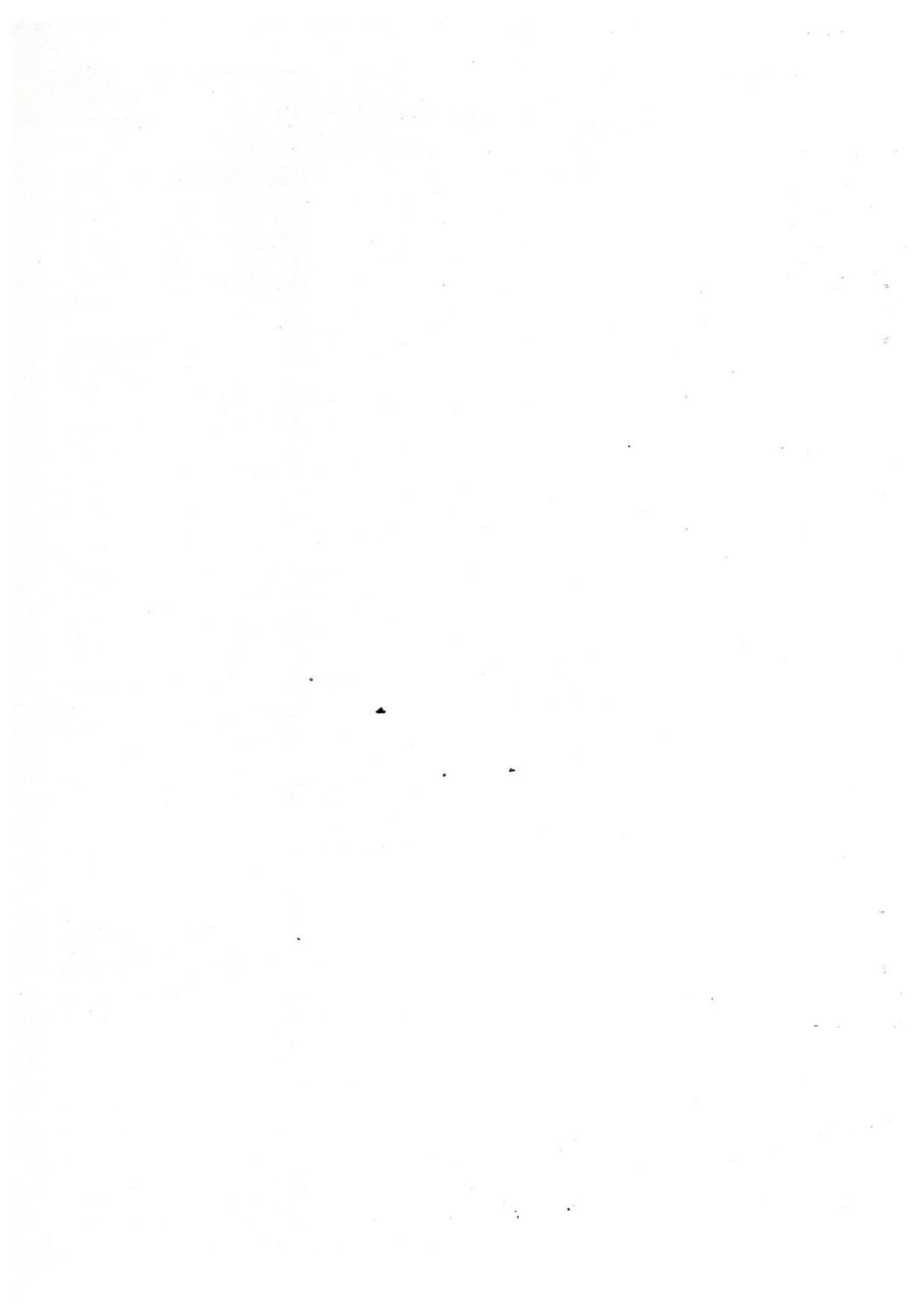



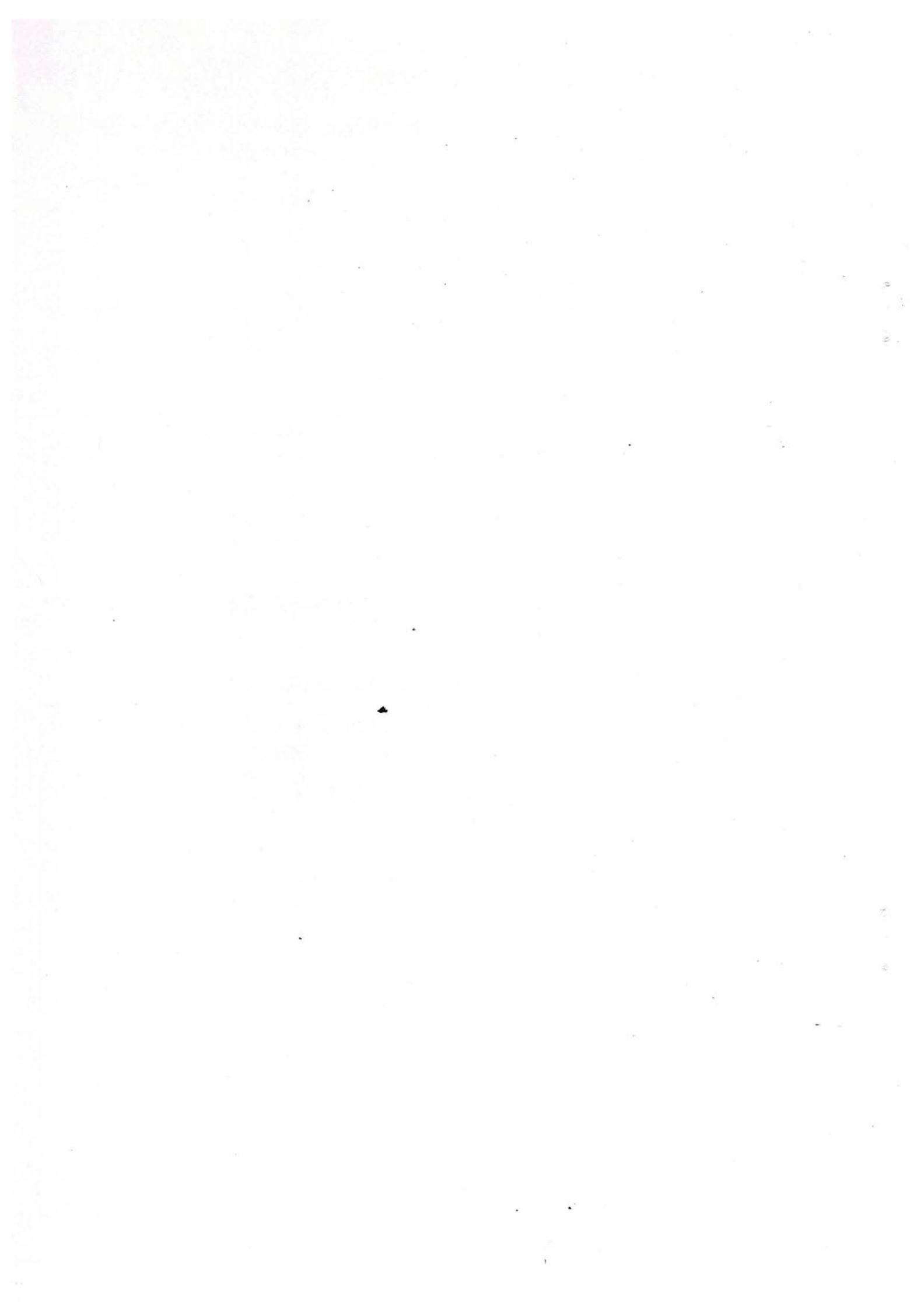

STATE ENVIRONMENT IMPACT ASSESSMENT AUTHORITY HARYANA  
Bay No. 55-58, Prayatan Bhawan, Sector-2, PANCHKULA.

No. SEIAA/HR/2014 / 1385

Dated: 07-11-2014.....

To

The Project Director,  
GCNEP, Department of Atomic Energy,  
Government of India, Reactor Control Division,  
Bhabha Atomic Research Centre,  
Trombay, Mumbai-400085

**Subject:** Environmental Clearance for construction of Institutional Campus and Residential Township for Global Centre for Nuclear Energy Partnership (GCNEP) at Village Kheri Jasaur and Jasaur Kheri District Jhajjar in the state of Haryana.

Dear Sir,

This letter is in reference to your application no. GCNEP/82 dated 26.12.2013 addressed to M.S. SEIAA, Haryana received on 30.12.2013 and subsequent letter dated 10.03.2014 seeking prior Environmental Clearance for the above project under the EIA Notification, 2006. The proposal has been appraised as per prescribed procedure in the light of provisions under the EIA Notification, 2006 on the basis of the mandatory documents enclosed with the application viz., Form-1, Form1-A, Conceptual Plan and additional clarifications furnished in response to the observations of the State Expert Appraisal Committee (SEAC) constituted by MOEF, GOI vide their Notification 23.3.2012, in its meetings held on 27.01.2014, 28.04.2014, 22.07.2014, 13.08.2014 and 09.09.2014 awarded "Gold" grading to the project.

[2] It is inter-alia, noted that the project involves the construction of Institutional Campus and Residential Township for Global Centre for Nuclear Energy Partnership (GCNEP) at village Kheri Jasaur and Jasaur Kheri District Jhajjar in the state of Haryana on a plot area of 113.66 Acres (46.39 hect = 32.73 for campus+ 13.66 hect from township). The proposed total built up area shall be 26432 sqm (18489 smt institutional campus + 7953 sqm residential township). The project shall comprise of Institutional Campus shall have central building, SNSS, SARRT and Service buildings. The project proponent has proposed to seek separate environment clearance for development of the remaining part of project as per the procedure laid down in the notification under expansion after the approval of the competent authority in Govt. of India is obtained. The total water requirement shall be 463 KLD. The waste water generation shall be 106.40 KLD, which will be treated in the 02 STPs having capacity of 67 KLD and 60 KLD. The entire treated water shall be recycled and re-used. The total power requirement shall be 1700 KVA which will be supplied by HBVNL. The Project Proponent has proposed to develop green belt on 32% for the institutional campus and 30.08% for residential township. The Project Proponent proposed to construct 50 rain

water harvesting pits. The solid waste generation will be 1530 kg/day. The bio-degradable waste will be treated in the project area by adopting appropriate technology. The total parking spaces proposed are 395 ECS.

[3] The State Expert Appraisal Committee, Haryana after due consideration of the relevant documents submitted by the project proponent and additional clarification furnished in response to its observations, have recommended the grant of environmental clearance for the project mentioned above, subject to compliance with the stipulated conditions. Accordingly, the State Environment Impact Assessment Authority in its meeting held on 14.10.2014 decided to agree with the recommendations of SEAC to accord necessary environmental clearance for the project under Category 8(a) of EIA Notification 2006 subject to the strict compliance with the specific and general conditions mentioned below:-

**PART A-**  
**SPECIFIC CONDITIONS:-**

**Construction Phase:-**

- [1] "Consent for Establish" shall be obtained from Haryana State Pollution Control Board under Air and Water Act and a copy shall be submitted to the SEIAA, Haryana before the start of any construction work at site.
- [2] A first aid room as proposed in the project report shall be provided both during construction and operational phase of the project.
- [3] Adequate drinking water and sanitary facilities shall be provided for construction workers at the site. Provision should be made for mobile toilets. Open defecation by the labourers is strictly prohibited. The safe disposal of waste water and solid wastes generated during the construction phase should be ensured.
- [4] All the topsoil excavated during construction activities shall be stored for use in horticulture/landscape development within the project site.
- [5] The project proponent shall ensure that the building material required during construction phase is properly stored within the project area and disposal of construction waste should not create any adverse effect on the neighboring communities and should be disposed of after taking necessary precautions for general safety and health aspects of people, only in approved sites with the approval of competent authority.
- [6] Construction spoils, including bituminous material and other hazardous materials, must not be allowed to contaminate watercourses and the dump sites for such material must be secured so that they should not leach into the ground water and any hazardous waste generated during construction phase, should be disposed off as per applicable rules and norms with necessary approval of the Haryana State Pollution Control Board.

- [7] The diesel generator sets to be used during construction phase shall be of ultra low sulphur diesel type and should conform to Environment (Protection) Rules prescribed for air and noise emission standards.
- [8] The diesel required for operating DG sets shall be stored in underground tanks and if required, clearance from Chief Controller of Explosives shall be taken.
- [9] Ambient noise levels shall conform to the residential standards both during day and night. Incremental pollution loads on the ambient air and noise quality should be closely monitored during construction phase. Adequate measures should be taken to reduce ambient air pollution and noise level during construction phase, so as to conform to the stipulated residential standards of CPCB/MoEF.
- [10] Fly ash shall be used as building material in the construction as per the provisions of Fly Ash Notification of September 1999 and as amended on 27th August 2003.
- [11] Storm water control and its re-use as per CGWB and BIS standards for various applications should be ensured.
- [12] Water demand during construction shall be reduced by use of pre-mixed concrete, curing agents and other best practices.
- [13] Roof must meet prescriptive requirement as per Energy Conservation Building Code by using appropriate thermal insulation material.
- [14] Opaque wall must meet prescriptive requirement as per Energy Conservation Building Code which is proposed to be mandatory for all air conditioned spaces while it is desirable for non-air-conditioned spaces by use of appropriate thermal insulation material to fulfill requirement.
- [15] The approval of the competent authority shall be obtained for structural safety of the building on account of earthquake, adequacy of fire fighting equipments, etc. as per National Building Code including protection measures from lightning etc. If any forest land is involved in the proposed site, clearance under Forest Conservation Act shall be obtained from the competent Authority.
- [16] The Project Proponent as stated in proposal shall construct 50 nos. rain water harvesting pits for recharging the ground water within the project premises. Rain water harvesting pits shall be designed to make provisions for silting chamber and removal of floating matter before entering harvesting pit. Maintenance budget and persons responsible for maintenance must be provided. Care shall also be taken that contaminated water do not enter any RWH pit.
- [17] The project proponent shall provide for adequate fire safety measures and equipments as required by Haryana Fire Service Act, 2009 and instructions issued by the local Authority/Directorate of fire from time to time. Further the project proponent shall take necessary permission regarding fire safety scheme/NOC from competent Authority as required.

- [18] The Project Proponent shall obtain assurance from the HBVNL for supply of 1700 KVA of power supply before the start of construction. In no case project will be operational solely on generators without any power supply from any external power utility.
- [19] Detail calculation of power load and ultimate power load of the project shall be submitted to HBVNL under intimation to SEIAA Haryana before the start of construction. Provisions shall be made for electrical infrastructure in the project area.
- [20] The Project Proponent shall not raise any construction in the natural land depression / Nallah/water course and shall ensure that the natural flow from the Nallah/water course is not obstructed.
- [21] The Project Proponent shall keep the plinth level of the building blocks sufficiently above the level of the approach road to the Project. Levels of the other areas in the Projects shall also be kept suitably so as to avoid flooding.
- [22] Construction shall be carried out so that density of population does not exceed norms approved by Director General Town and Country Department Haryana.
- [23] The Project Proponent shall submit an affidavit with the declaration that ground water will not be used for construction and only treated water should be used for construction.
- [24] The project proponent shall not cut any existing tree and project landscaping plan should be modified to include those trees in green area.
- [25] The project proponent shall ensure that ECBC norms for composite climate zone are met. In particular building envelope, HVAC service, water heating, pumping, lighting and electrical infrastructure must meet ECBC norms.
- [26] The Project Proponent shall provide 2 meter high barricade around the project area, dust screen for every floor above the ground, proper sprinkling and covering of stored material to restrict dust and air pollution during construction.
- [27] The project proponent shall construct a sedimentation basin in the lower level of the project site to trap pollutant and other wastes during rains.
- [28] The project proponent shall provide proper rasta of proper width and proper strength for the project before the start of construction.
- [29] The project proponent shall ensure that the U-value of the glass is less than 3.177 and maximum solar heat gain co-efficient is 0.25 for vertical fenestration.
- [30] The project proponent shall adequately control construction dusts like silica dust, non-silica dust and wood dust. Such dusts shall not spread outside project premises. Project Proponent shall provide respiratory protective equipment to all construction workers.
- [31] The project proponent shall provide fire control room and fire officer for building above 30 meter as per National Building Code.



- [32] The project proponent shall obtain permission of Mines and Geology Department for excavation of soil before the start of construction.
- [33] The project proponent shall seek specific prior approval from concerned local Authority/HUDA regarding provision of storm drainage and sewerage system including their integration with external services of HUDA/ Local authorities beside other required services before taking up any construction activity.
- [34] The site for solid waste management plant be earmarked on the layout plan and the detailed project for setting up the solid waste management plant shall be submitted to the Authority within one month.
- [35] The project proponent shall discharge excess of treated waste water/storm water in the public drainage system and shall seek permission of HUDA before the start of construction.
- [36] The project proponent shall ensure that structural stability to withstand earthquake of magnitude 8.5 on Richter scale.
- [37] The project proponent shall seek separate environment clearance for development of the remaining part of project as per the procedure laid down in the notification under expansion after the approval of the competent authority in Govt. of India is obtained.
- [38] The project proponent shall be self integrated with respect to services infrastructure and shall be independent for all the purposes.

**Operational Phase:**

- [a] "Consent to Operate" shall be obtained from Haryana State Pollution Control Board under Air and Water Act and a copy shall be submitted to the SEIAA, Haryana.
- [b] The Sewage Treatment Plant (STP) shall be installed for the treatment of the sewage to the prescribed standards including odour and treated effluent will be recycled to achieve zero exit discharge. The installation of STP shall be certified by an independent expert and a report in this regard shall be submitted to the SEIAA, Haryana before the project is commissioned for operation. Tertiary treatment of waste water is mandatory. The project proponent shall remove not only Ortho-Phosphorus but total Phosphorus to the extent of less than 2mg/liter. Similarly total Nitrogen level shall be less than 2mg/liter in tertiary treated waste water. Discharge of treated sewage shall conform to the norms and standards of CPCB/ HSPCB, whichever is environmentally better. Project Proponent shall implement such STP technology which does not require filter backwash.
- [c] Separation of the grey and black water should be done by the use of dual plumbing line. Treatment of 100% grey water by decentralized treatment should be done

ensuring that the re-circulated water should have BOD level less than 5 mg/litre and the recycled water will be used for flushing, gardening and DG set cooling etc.

- [d] For disinfection of the treated wastewater ultra-violet radiation or ozonization process should be used.
- [e] Diesel power generating sets proposed as source of back-up power for lifts, common area illumination and for domestic use should be of enclosed type and conform to rules made under the Environment (Protection) Act, 1986. The location of the DG sets shall be in the basement as promised by the project proponent with appropriate stack height above the highest roof level of the project as per the CPCB norms. The diesel used for DG sets shall be ultra low sulphur diesel (35 ppm sulphur), instead of low sulphur diesel.
- [f] Ambient Noise level should be controlled to ensure that it does not exceed the prescribed standards both within and at the boundary of the Proposed Institutional Campus & Residential Township.
- [g] The project proponent as stated in the proposal shall maintain at least 32% for the institutional campus and 30.08% for residential township as green cover area for tree plantation especially all around the periphery of the project and on the road sides preferably with local species which can provide protection against noise and suspended particulate matter. The open spaces inside the project shall be preferably landscaped and covered with vegetation/grass, herbs & shrubs. Only locally available plant species shall be used.
- [h] The project proponent shall strive to minimize water in irrigation of landscape by minimizing grass area, using native variety, xeriscaping and mulching, utilizing efficient irrigation system, scheduling irrigation only after checking evapo-transpiration data.
- [i] The ground water level and its quality should be monitored regularly in consultation with Central Ground Water Authority.
- [j] A report on the energy conservation measures conforming to energy conservation norms finalized by Bureau of Energy Efficiency should be prepared incorporating details about building materials & technology, R & U Factors etc and submitted to the SEIAA, Haryana in three months time.
- [k] Energy conservation measures like installation of LED only for lighting the areas outside the building and inside the building should be integral part of the project design and should be in place before project commissioning. Use of solar panels must be adapted to the maximum energy conservation.
- [l] The Project Proponent shall use zero ozone depleting potential material in insulation, refrigeration, air-conditioning and adhesive. Project Proponent shall also provide halon free fire suppression system.

- [m] The solid waste generated should be properly collected and segregated as per the requirement of the MSW Rules, 2000 and as amended from time to time. The bio-degradable waste should be treated by appropriate technology at the site ear-marked within the project area and dry/inert solid waste should be disposed off to the approved sites for land filling after recovering recyclable material.
- [n] The provision of the solar water heating system shall be as per norms specified by HAREDA and shall be made operational in each building block.
- [o] The traffic plan and the parking plan proposed by the Project Proponent should be meticulously adhered to with further scope of additional parking for future requirement. There should be no traffic congestion near the entry and exit points from the roads adjoining the proposed project site. Parking should be fully internalized and no public space should be used.
- [p] The Project shall be operationalized only when HUDA/local authority will provide domestic water supply system in the area.
- [q] Operation and maintenance of STP, solid waste management and electrical Infrastructure, pollution control measures shall be ensured even after the completion of project.
- [r] Different type of wastes should be disposed off as per provisions of municipal solid waste, biomedical waste, hazardous waste, e-waste, batteries & plastic rules made under Environment Protection Act, 1986. Particularly E-waste and Battery waste shall be disposed of as per existing E-waste Management Rules 2011 and Batteries Management Rules 2001. The project proponent shall maintain a collection center for E-waste and it shall be disposed of to only registered and authorized dismantler / recycler as per existing E-waste Management Rules 2011.
- [s] Standards for discharge of environmental pollutants as enshrined in various schedules of rule 3 of Environment Protection Rule 1986 shall be strictly complied with.
- [t] The project proponent shall make provision for guard pond and other provisions for safety against failure in the operation of wastewater treatment facilities. The project proponent shall also identify acceptable outfall for treated effluent.
- [u] The project proponent shall ensure that the stack height of DG sets is as per the CPCB guide lines and also ensure that the emission standards of noise and air are within the CPCB latest prescribed limits. Noise and Emission level of DG sets greater than 800 KVA shall be as per CPCB latest standards for high capacity DG sets.
- [v] All electric supply exceeding 100 amp, 3 phase shall maintain the power factor between 0.98 lag to 1 at the point of connection.
- [w] The project proponent shall minimize heat island effect through shading and reflective or pervious surface instead of hard surface.

- [x] The project proponent shall not use fresh water for HVAC and DG cooling. Air based HVAC system should be adopted and only treated water shall be used by project proponent for cooling, if it is at all needed. The Project Proponent shall also use evaporative cooling technology and double stage cooling system for HVAC in order to reduce water consumption. Further temperature, relative humidity during summer and winter seasons should be kept at optimal level. Variable speed drive, best Co-efficient of Performance (CoP), as well as optimal Integrated Point Load Value and minimum outside fresh air supply may be resorted for conservation of power and water. Coil type cooling DG Sets shall be used for saving cooling water consumption for water cooled DG Sets.
- [y] The project proponent shall ensure that the transformer is constructed with high quality grain oriented, low loss silicon steel and virgin electrolyte grade copper. The project proponent shall obtain manufacturer's certificate also for that.
- [z] Water supply shall be metered among different users and different utilities.
- [aa] The project proponent shall ensure that exit velocity from the stack should be sufficiently high. Stack shall be designed in such a way that there is no stack down-wash under any meteorological conditions.
- [ab] The project proponent shall provide water sprinkling system in the project area to suppress the dust in addition to the already suggested mitigation measures in the Air Environment Chapter of EMP.
- [ac] The project proponent shall provide additional green area on terrace and roof top.
- [ad] The project proponent shall ensure proper Air Ventilation and light system in the basements area for comfortable living of human being and shall ensure that number of Air Changes per hour/(ACH) in basement never falls below 15. In case of emergency capacity for increasing ACH to the extent of 30 must be provided by the project proponent.
- [ae] The project proponent shall install solar panel for energy conservation.

**PART-B. GENERAL CONDITIONS:**

- [i] The Project Proponent shall ensure the commitments made in Form-1, Form-1A, EIA/EMP and other documents submitted to the SEIAA for the protection of environment and proposed environmental safeguards are complied with in letter and spirit. In case of contradiction between two or more documents on any point, the most environmentally friendly commitment on the point shall be taken as commitment by project proponent.
- [ii] The project proponent shall also submit six monthly reports on the status of compliance of the stipulated EC conditions including results of monitored data (both in hard copies as well as by e-mail) to the northern Regional Office of MoEF, the respective Zonal Office of CPCB, HSPCB and SEIAA Haryana.

- [iii] STP outlet after stabilization and stack emission shall be monitored monthly. Other environmental parameters and green belt shall be monitored on quarterly basis. After every 3 (three) months, the project proponent shall conduct environmental audit and shall take corrective measure, if required, without delay.
- [iv] The SEIAA, Haryana reserves the right to add additional safeguard measures subsequently, if found necessary. Environmental Clearance granted will be revoked if it is found that false information has been given for getting approval of this project. SEIAA reserves the right to revoke the clearance if conditions stipulated are not implemented to the satisfaction of SEIAA/MoEF.
- [v] The Project proponent shall not violate any judicial orders/pronouncements issued by any Court/Tribunal.
- [vi] All other statutory clearances such as the approvals for storage of diesel from Chief Controller of Explosives, Fire Department, Civil Aviation Department, Forest Conservation Act, 1980 and Wildlife (Protection) Act, 1972, Forest Act, 1927, PLPA 1900, etc. shall be obtained, as applicable by project proponents from the respective authorities prior to construction of the project.
- [vii] The Project proponent should inform the public that the project has been accorded Environment Clearance by the SEIAA and copies of the clearance letter are available with the Haryana State Pollution Control Board & SEIAA. This should be advertised within 7 days from the date of issue of the clearance letter at least in two local newspapers that are widely circulated in the region and the copy of the same should be forwarded to SEIAA Haryana. A copy of Environment Clearance conditions shall also be put on project proponent's web site for public awareness.
- [viii] Under the provisions of Environment (Protection) Act, 1986, legal action shall be initiated against the Project Proponent if it was found that construction of the project has been started before obtaining prior Environmental Clearance.
- [ix] Any appeal against the this Environmental Clearance shall lie with the National Green Tribunal, if preferred, within a period of 30 days as prescribed under Section 16 of the National Green Tribunal Act, 2010.
- [x] The project proponent shall put in place Corporate Environment Policy as mentioned in MoEF, GoI OM No. J-11013/41/2006-IA II (I) dated 26.4.2012 within 3 months period. Latest Corporate Environment Policy should be submitted to SEIAA within 3 months of issuance of this letter.
- [xi] The fund ear-marked for environment protection measures should be kept in separate account and should not be diverted for other purposes and year wise expenditure shall be reported to the SEIAA/RO MoEF, GoI under rules prescribed for Environment Audit.
- [xii] The project proponent shall ensure the compliance of Forest Department, Haryana Notification no. S.O.121/PA2/1900/S.4/97 dated 28.11.1997.

- [xiii] The Project Proponent shall ensure that no vehicle during construction/operation phase enter the project premises without valid 'Pollution Under Control' certificate from competent Authority.
- [xiv] The project proponent shall seek fresh Environmental clearance if at any stage there is change in the planning of the proposed project.
- [xv] Nodal Officer (Project Director) nominated by GCNEP shall be responsible for implementation of all conditions of Environmental Clearance letter.
- [xvi] The proponent shall upload the status of compliance of the stipulated EC conditions, including results of monitored data on their website and shall update the same periodically. It shall simultaneously be sent to the Regional Office of MoEF, the respective Zonal Office of CPCB and the SPCB. The criteria pollutant levels namely; PM<sub>2.5</sub>, PM<sub>10</sub>, SO<sub>x</sub>, NO<sub>x</sub>, Ozone, Lead, CO, Benzene, Ammonia, Benzopyrine, arsenic and Nickel. (Ambient levels as well as stack emissions) or critical sectoral parameters, indicated for the project shall be monitored and displayed at a convenient location near the main gate of the company in the public domain.
- [xvii] The environmental statement for each financial year ending 31<sup>st</sup> March in Form-V as is mandated to be submitted by the project proponent to the HSPCB Panchkula as prescribed under the Environment (Protection) Rules, 1986, as amended subsequently, shall also be put on the website of the company along with the status of compliance of the EC conditions and shall also be sent to the respective Regional Offices of MoEF by e-mail.
- [xviii] The project proponent shall conduct environment audit at every three months interval and thereafter corrected measures shall be taken without any delay. Details of environmental audit and corrective measures shall be submitted in the monitoring report.

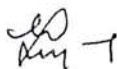

Member Secretary,  
State Level Environment Impact  
Assessment Authority, Haryana, Panchkula.

Endst. No. SEIAA/HR/2014

Dated:.....

A copy of the above is forwarded to the following:

1. The Additional Director (IA Division), MOEF, GOI, Indra Paryavaran Bhavan, Zor bagh Road-New Delhi.
2. The Regional office, Ministry of Environment & Forests, Govt. of India, Sector 31, Chandigarh.
3. The Chairman, Haryana State Pollution Control Board, Pkl.

Member Secretary,  
State Level Environment Impact  
Assessment Authority, Haryana, Panchkula